

Thermalright

Macho Rev. A

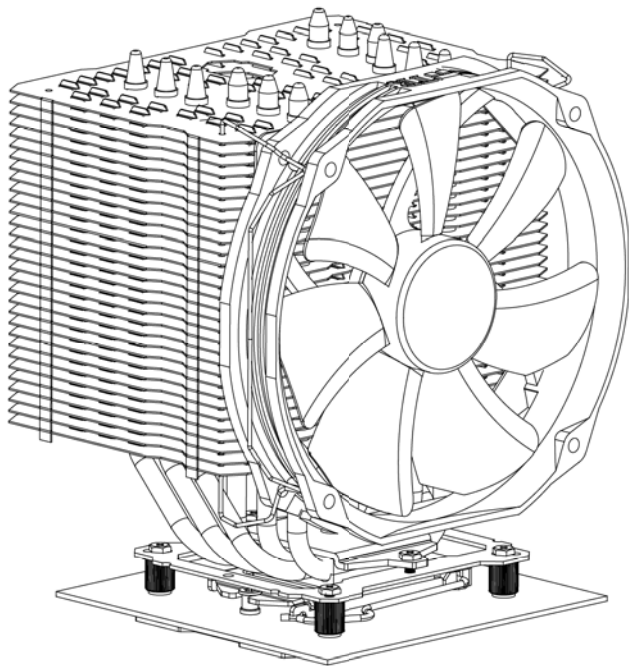

Macho Rev. A

Assembly package



x 4



x 1



x 4



x 4

4



x 7



x 4



x 5



x 4

4



x 1



x 1



x 1



x 2

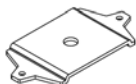

x 1



x 1







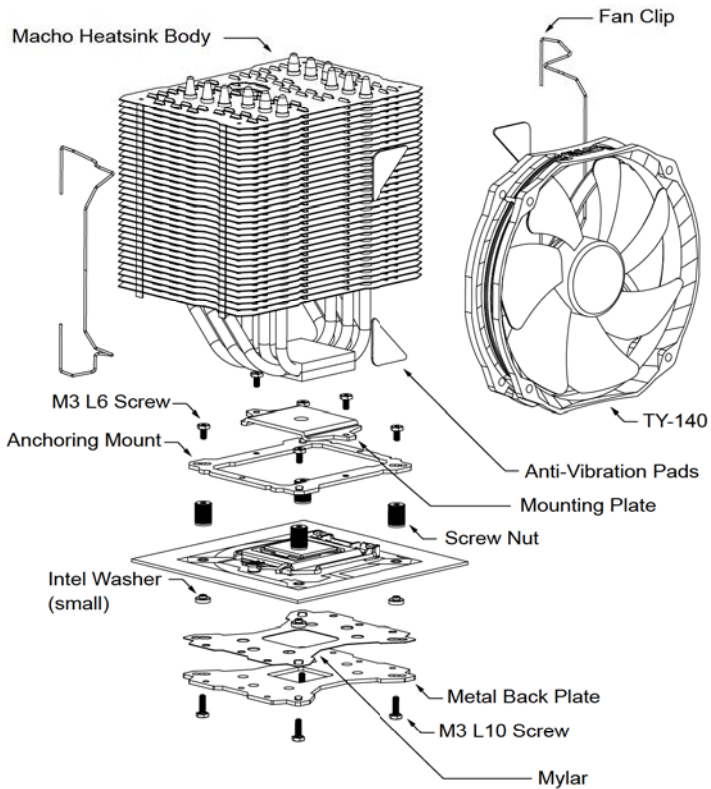



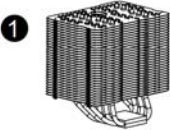

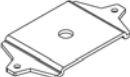



8

Exploded View

Important! Before proceeding with installation, please check for the most up-to-date instructions at www.thermalright.com

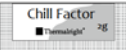

Component

		
		
		
		
		
		
		
1 Macho Heatsink Body ×1	2 Anchoring Mount ×1	3 Metal Back Plate ×1
4 Mounting Plate ×1	5 Screw Nut ×4	6 LGA2011 Type B Screw Pillars ×4
7 M3 L10 Screw ×5	8 M3 L6 Screw ×7	9 Intel Washer (small) ×4
10 AMD Washer (big) ×4	11 Anti-Vibration Pad ×4	12 Backplate cap ×1
13 Fan Clip ×2	14 Thermal paste ×1	15 Screw driver ×1
16 TY-140 ×1	17 Mylar ×1	

Installation Instructions:

Step 1:

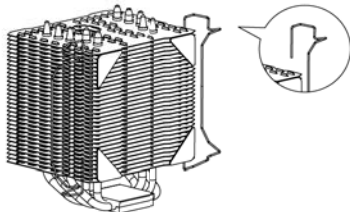

Step 1 : Part Installation

Take out Macho cooler from the paper box. Remove the TY-140 from the cooler by pulling the Fan Clips upwards in order to give room for ease of installation. And leave the Fan Clips on the Heatsink Body. Do not remove them. Apply Anti-Vibration Padding to 4 corners on the Heatsink Body.

Step 2:

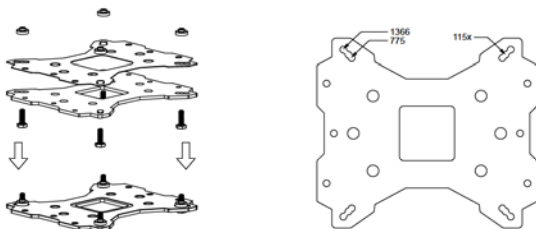

Step 2 : Backplate Installation

Choose the platform (775/1150/1155/1156/1366) you are in use. Make four M3L10 Screw Pillars go through the Metal Back Plate and the Mylar film from bottom towards top. And then place the Metal Back Plate on the table. Put the four Washers (for Intel) around the Screw Pillars.

Step 3:

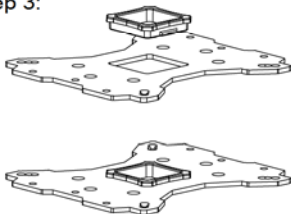

Step 3 : 775 backplate cap

Note: When installing on a 775 platform, please first insert the Back Plate Cap into the opening on the Back plate, make sure you have the Cap facing downwards. (Only for 775).

Step 4:

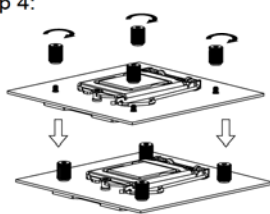

Step 4 : Place the motherboard on top of the Back Plate. See the four Screw Pillars go through the four holes around the processor socket. Cap the four Screw Pillars with the four Screw Nuts. Make sure the side with a washer is facing the Back Plate.

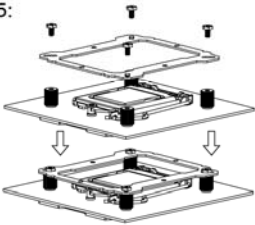
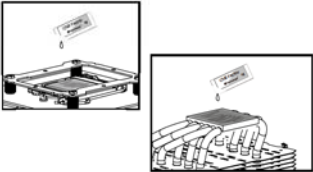
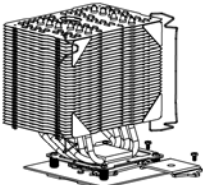
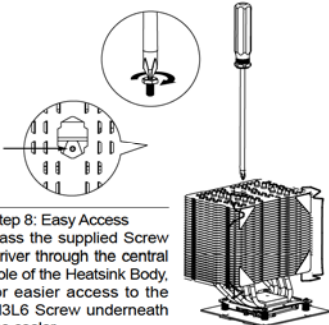
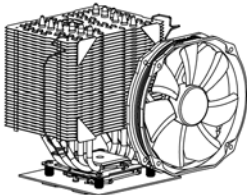
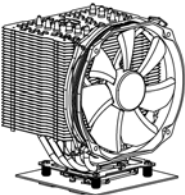





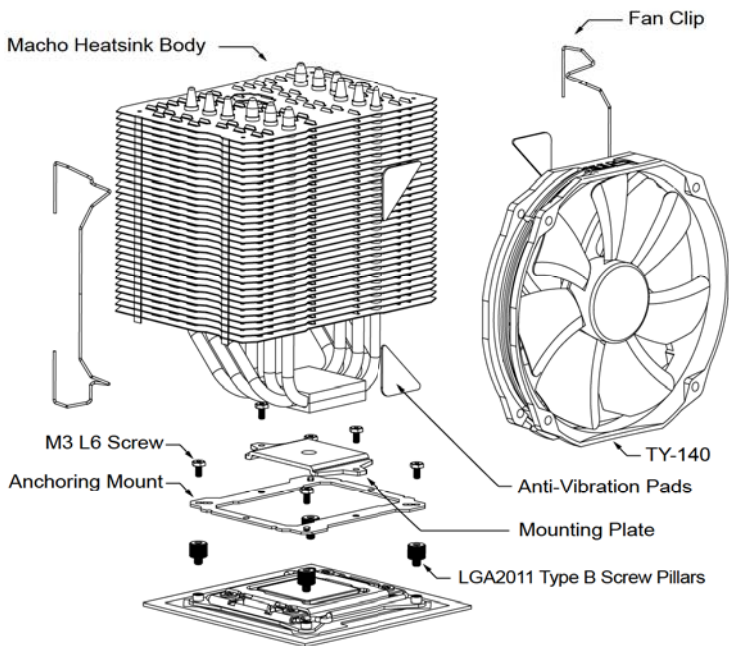



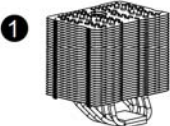

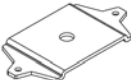



<p>Step 5:</p> 	<p>Step 6:</p> 
<p>Step 5 : Place the Anchoring Mount on the Screw Nuts. Use the four M3L6 Screws to fix the Anchoring Mount on to the Screw Pillars.</p>	<p>Step 6 : Applying Thermal Paste Apply the Thermal Paste to the base of the Heatsink and the surface of the CPU evenly.</p>
<p>Step 7:</p> 	<p>Step 8:</p> 
<p>Step 7: Mounting Plate Installation Place the Heatsink Body on top of the CPU. Make the Mounting Plate go through the Heatsink Body. Then use the supplied Screw Driver to fasten the two M3L6 Screws to Secure the Mounting Plate.</p>	<p>Step 8: Easy Access Pass the supplied Screw Driver through the central hole of the Heatsink Body, for easier access to the M3L6 Screw underneath the cooler.</p>
<p>Step 9:</p> 	<p>Step 10:</p> 
<p>Step 9 : Fan Installation Place the included TY-140 onto the Heatsink Body. And then secure it with the Fan Clips, by pulling the Fan Clips to place the four ends at the four holes on the TY-140.</p>	<p>Step 10 : Installation completed Plug in the fan connector to the CPU PWM Fan socket on the motherboard. Installation complete.</p>

Exploded View

Important! Before proceeding with installation, please check for the most up-to-date instructions at www.thermalright.com



Component

		
		
		
		
		
		
		
1 Macho Heatsink Body ×1	2 Anchoring Mount ×1	3 Metal Back Plate ×1
4 Mounting Plate ×1	5 Screw Nut ×4	6 LGA2011 Type B Screw Pillars ×4
7 M3 L10 Screw ×5	8 M3 L6 Screw ×7	9 Intel Washer (small) ×4
10 AMD Washer (big) ×4	11 Anti-Vibration Pad ×4	12 Backplate cap ×1
13 Fan Clip ×2	14 Thermal paste ×1	15 Screw driver ×1
16 TY-140 ×1	17 Mylar ×1	

Installation Instructions:

Step 1:

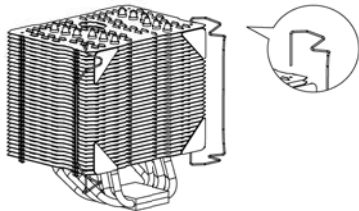

Step 1 : Part Installation

Take out Macho cooler from the paper box. Remove the TY-140 from the cooler by pulling the Fan Clips upwards in order to give room for ease of installation. And leave the fan clips on the Heatsink Body. Do not remove them. Apply Anti-Vibration Padding to 4 corners on the Heatsink Body.

Step 2:

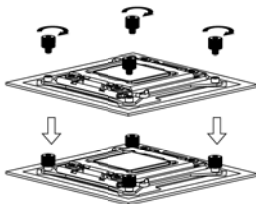

Step 2 : Screw Pillar Installation

Place the motherboard on top of the Back Plate. See the four Screw Pillars go through the four holes around the processor socket. Cap the four Screw Pillars with the four Screw Nuts. Make sure the side with a washer is facing the Back Plate.

Step 3:

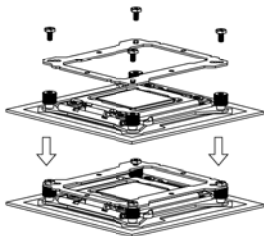

Step 3 : Anchoring Mount Installation

Place the Anchoring Mount on the Screw Nuts. Use the four M3L6 Screws to fix the Anchoring Mount on to the Screw Pillars.

Step 4:

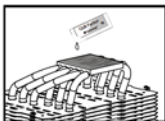

Step 4 : Applying Thermal Paste

Apply the Thermal Paste to the base of the Heatsink and the surface of the CPU evenly.

Step 5:

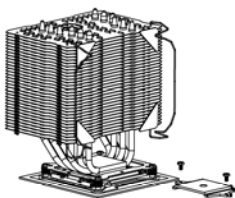

Step 5: Mounting Plate Installation

Place the Heatsink Body on top of the CPU. Make the Mounting Plate go through the Heatsink Body. Then use the supplied Screw Driver to fasten the two M3L6 Screws to Secure the Mounting Plate.

Step 6:

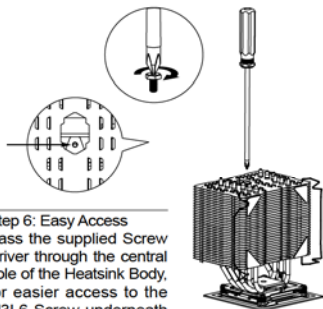

Step 6: Easy Access

Pass the supplied Easy Access Screw Driver through the central hole of the Heatsink Body, for easier access to the M3L6 Screw underneath the cooler.

Step 7:

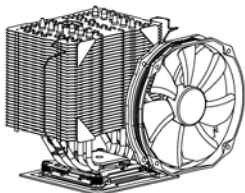

Step 7 : Fan Installation

Place the included TY-140 onto the Heatsink Body. And then secure it with the Fan Clips, by pulling the Fan Clips to place the four ends at the four holes on the TY-140.

Step 8:

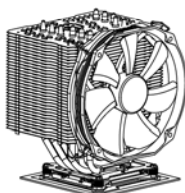

Step 8 : Installation completed







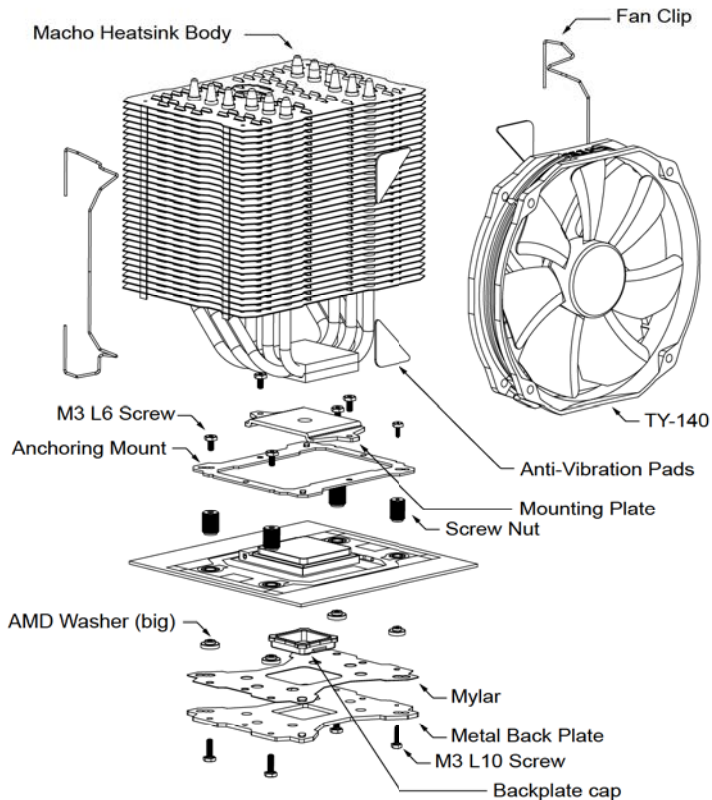



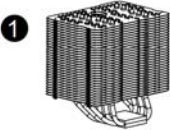

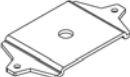



Plug in the fan connector to the CPU PWM Fan socket on the motherboard. Installation complete.

Exploded View

Important! Before proceeding with installation, please check for the most up-to-date instructions at www.thermalright.com



Component

		
		
		
		
		
		
		
1 Macho Heatsink Body ×1	2 Anchoring Mount ×1	3 Metal Back Plate ×1
4 Mounting Plate ×1	5 Screw Nut ×4	6 LGA2011 Type B Screw Pillars ×4
7 M3 L10 Screw ×5	8 M3 L6 Screw ×7	9 Intel Washer (small) ×4
10 AMD Washer (big) ×4	11 Anti-Vibration Pad ×4	12 Backplate cap ×1
13 Fan Clip ×2	14 Thermal paste ×1	15 Screw driver ×1
16 TY-140 ×1	17 Mylar ×1	

Installation Instructions:

Step 1:

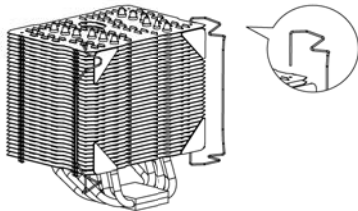

Step 1 : Part Installation

Take out Macho cooler from the paper box. Remove the TY-140 from the cooler by pulling the Fan Clips upwards in order to give room for ease of installation. And leave the Fan Clips on the Heatsink Body. Do not remove them. Apply Anti-Vibration Padding to 4 corners on the Heatsink Body.

Step 2:

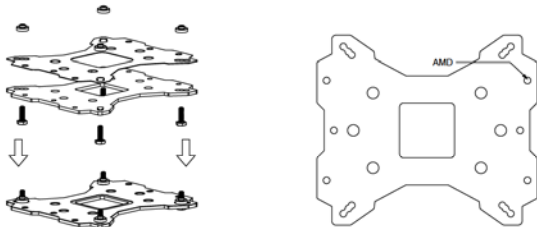

Step 2 : Backplate Installation

Choose the platform (AMD) you are in use. Make four M3L10 Screw Pillars go through the Metal Back Plate and the Mylar film from bottom towards top. And then place the Metal Back Plate on the table. Put the four Washers (for AMD) around the Screw Pillars.

Step 3:

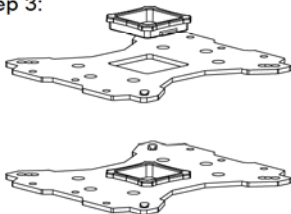

Step 3 : backplate cap

Note: When installing on a 939 platform, please first insert the Back Plate Cap into the opening on the Back plate, make sure you have the Cap facing downwards. (Only for 939).

Step 4:

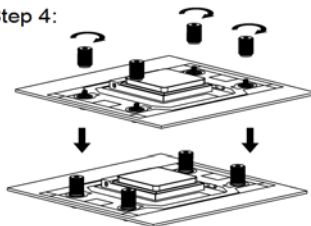

Step 4 : Place the motherboard on top of the Back Plate. See the four Screw Pillars go through the four holes around the processor socket. Cap the four Screw Pillars with the four Screw Nuts. Make sure the side with a washer is facing the Back Plate.

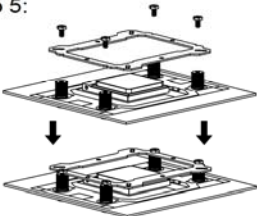
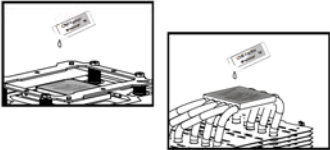
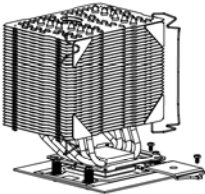
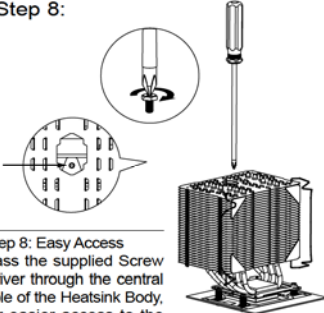
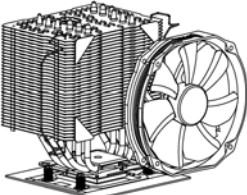
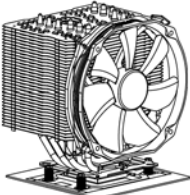





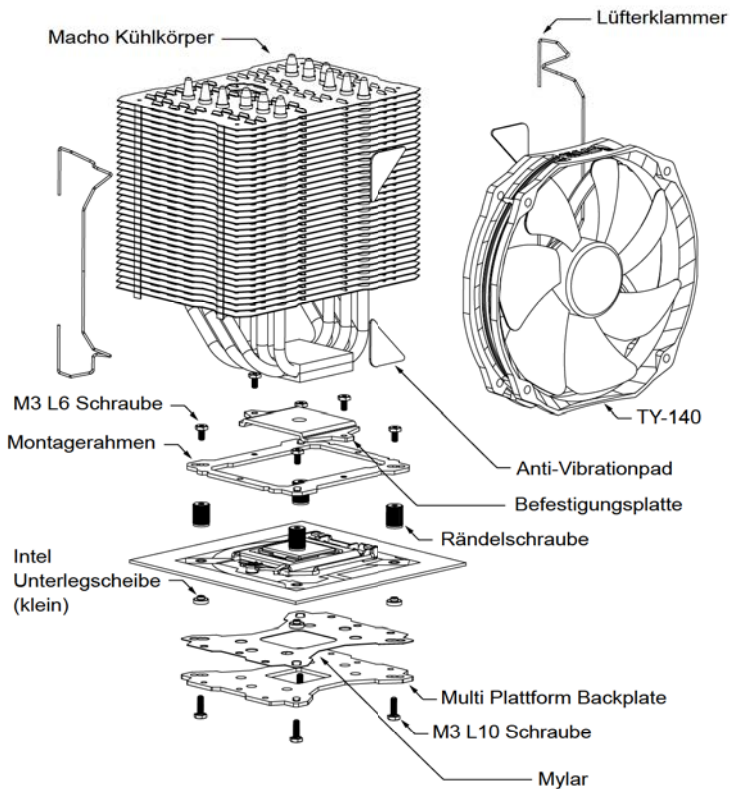



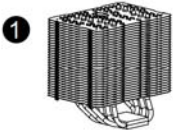

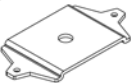



<p>Step 5:</p> 	<p>Step 6:</p> 
<p>Step 5 : Place the Anchoring Mount on the Screw Nuts. Use the four M3L6 Screws to fix the Anchoring Mount on to the Screw Pillars.</p>	<p>Step 6 : Applying Thermal Paste Apply the Thermal Paste to the base of the Heatsink and the surface of the CPU evenly.</p>
<p>Step 7:</p> 	<p>Step 8:</p> 
<p>Step 7: Mounting Plate Installation Place the Heatsink Body on top of the CPU. Make the Mounting Plate go through the Heatsink Body. Then use the supplied Screw Driver to fasten the two M3L6 Screws to Secure the Mounting Plate.</p>	<p>Step 8: Easy Access Pass the supplied Screw Driver through the central hole of the Heatsink Body, for easier access to the M3L6 Screw underneath the cooler.</p>
<p>Step 9:</p> 	<p>Step 10:</p> 
<p>Step 9 : Fan Installation Place the included TY-140 onto the Heatsink Body. And then secure it with the Fan Clips, by pulling the Fan Clips to place the four ends at the four holes on the TY-140 .</p>	<p>Step 10 : Installation completed Plug in the fan connector to the CPU PWM Fan socket on the motherboard. Installation complete.</p>

Explosionszeichnung

Wichtig! Bitte prüfen Sie vor der Montage, ob für Ihren Kühler aktualisierte Montagehinweise auf der Webseite www.thermalright.com verfügbar sind.



Komponenten

				
				
				
				
1 Macho Kühlkörper ×1	2 Montagerahmen ×1	3 Multi Plattform Backplate×1		
4 Befestigungsplatte ×1	5 Rändelschraube ×4	6 LGA2011 Type B Adapterschraube x4		
7 M3 L10 Schraube ×5	8 M3 L6 Schraube ×7	9 Intel Unterlegscheibe (klein) ×4		
10 AMD Unterlegscheibe (groß) ×4	11 Anti-Vibrationspad ×4	12 Backplateeinsatz ×1		
13 Lüfterklammer ×2	14 Wärmeleitpaste ×1	15 Schraubendreher ×1		
16 TY-140 ×1	17 Leitschutzfolie ×1			

Installationsanleitung:

Schritt 1:

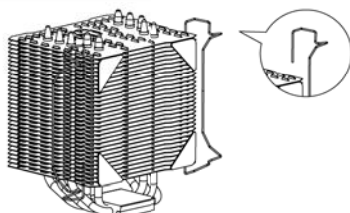

Nachdem Sie den Macho Kühler aus der Verpackung genommen haben demontieren Sie zunächst den Lüfter, um die Installation zu vereinfachen. Belassen Sie hierbei die Lüfterklammern am Kühlkörper - entfernen Sie diese nicht. Bringen Sie die vier selbstklebenden Anti-Vibrationspads an den Ecken des Kühlkörpers an.

Schritt 2:

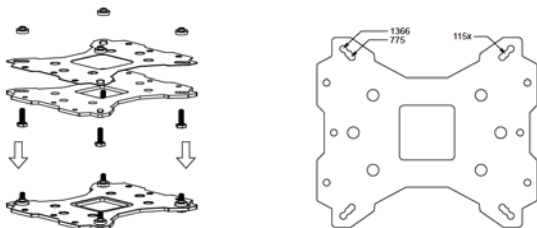

Achten Sie auf die für die entsprechenden Intel Sockel (775/1150/1155/1156/1366) vorgesehene Bohrungen in der Multi Plattform Backplate. Führen Sie die vier M3L10 Schrauben jeweils von unten durch die Backplate und die mitgelieferte Leitschutzfolie und legen dann die Backplate auf den Tisch. Legen Sie die vier Unterlegscheiben (für Intel) über die hervorstehenden Gewinde.

Schritt 3:

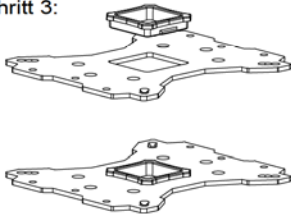

Beachten Sie:
Bei Verwendung einer Intel Sockel 775 Plattform setzen Sie zuerst den Backplateeinsatz in die quadratische Öffnung der Backplate ein. Gehen Sie sicher, dass der Aufsatz nach unten zeigt.

Schritt 4:

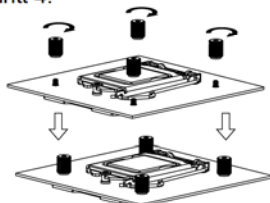

Platzieren Sie das Mainboard von oben auf die Backplate, so dass die hervorstehenden Schraubengewinde durch die Löcher um den Prozessorsockel gehen. Schrauben Sie die beiliegenden Rändelschrauben auf die vier Schraubengewinde. Achten Sie dabei darauf, dass die Seite mit der Unterlegscheibe zur Backplate zeigt.

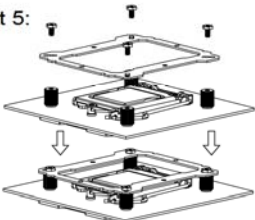
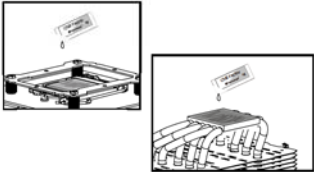
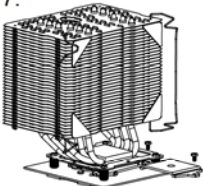
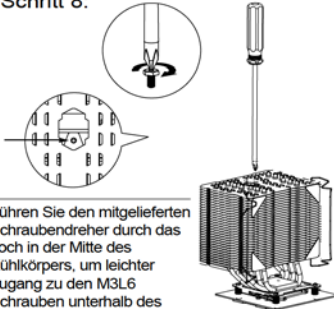
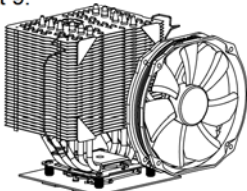
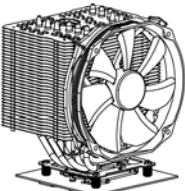
<p>Schritt 5:</p> 	<p>Schritt 6:</p> 
<p>Setzen Sie den Montagerahmen auf die Rändelschrauben. Verwenden Sie die vier M3L6 Schrauben, um den Montagerahmen auf den Rändelschrauben zu befestigen.</p>	<p>Tragen Sie eine hauchdünne Schicht Wärmeleitpaste auf der Oberfläche der CPU und auf der Unterseite des Kühlers auf.</p>
<p>Schritt 7:</p> 	<p>Schritt 8:</p> 
<p>Platzieren Sie nun den Kühlkörper auf die CPU. Führen Sie anschließend die Befestigungsplatte durch den Kühlkörper und benutzen die beiden M3L6 Schrauben, um die Befestigungsplatte zu befestigen.</p>	<p>Führen Sie den mitgelieferten Schraubendreher durch das Loch in der Mitte des Kühlkörpers, um leichter Zugang zu den M3L6 Schrauben unterhalb des Kühlers zu erhalten.</p>
<p>Schritt 9:</p> 	<p>Schritt 10:</p> 
<p>Positionieren Sie den mitgelieferten TY-140 auf die Kühlerseite mit den bereits angebrachten AntiVibrationspads. Nun sichern Sie den Lüfter mit den Lüfterklammern, indem Sie diese über den Lüfterrahmen klappen und die spitzwinkligen Ecken in die Montagelöcher des Lüfters einrasten lassen.</p>	<p>Verbinden Sie den Lüfterstecker mit dem CPU PWM Lüfteranschluss auf dem Mainboard. Die Installation ist nun abgeschlossen. Bitte prüfen Sie die ordnungsgemäße Funktion vor Inbetriebnahme Ihres PC.</p>

Explosionszeichnung

Wichtig! Bitte prüfen Sie vor der Montage, ob für Ihren Kühler aktualisierte Montagehinweise auf der Webseite www.thermalright.com verfügbar sind.

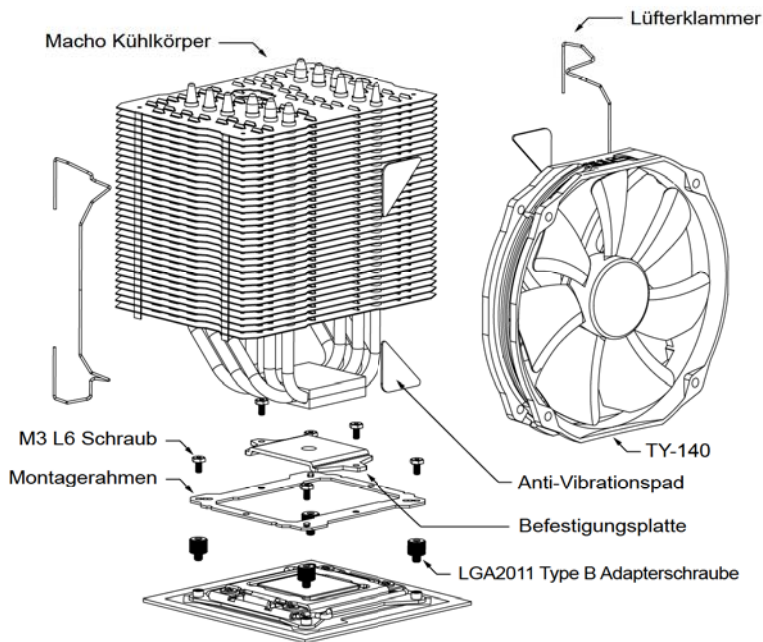

Component

1 Macho Kühlkörper ×1			2 Montagerahmen ×1			3 Multi Plattform Backplate×1		
4 Befestigungsplatte ×1			5 Rändelschraube ×4			6 LGA2011 Type B Adapterschraube x4		
7 M3 L10 Schraube ×5			8 M3 L6 Schraube ×7			9 Intel Unterlegscheibe (klein) ×4		
10 AMD Unterlegscheibe (groß) ×4			11 Anti-Vibrationspad ×4			12 Backplateeinsatz ×1		
13 Lüfterklammer ×2			14 Wärmeleitpaste ×1			15 Schraubendreher ×1		
16 TY-140 ×1			17 Leitschutzfolie ×1					

Installationsanleitung:

Schritt 1:

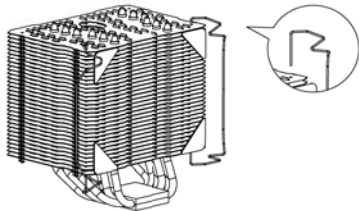

Nachdem Sie den Macho Kühler aus der Verpackung genommen haben demontieren Sie zunächst den Lüfter, um die Installation zu vereinfachen. Belassen Sie hierbei die Lüfterklammern am Kühlkörper - entfernen Sie diese nicht. Bringen Sie die vier selbstklebenden Anti-Vibrationspads an den Ecken des Kühlkörpers an.

Schritt 2:

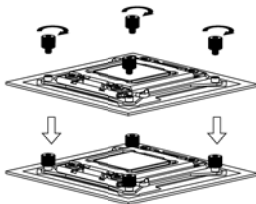

Schrauben Sie die vier LGA2011 Type B Adapterschrauben in die Gewinde des Montagerahmens, der sich um den Prozessorsockel befindet.

Schritt 3:

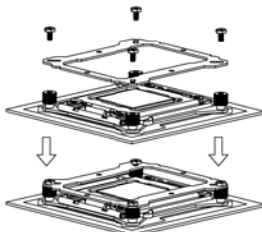

Setzen Sie den Montagerahmen auf die Rändelschrauben. Verwenden Sie die vier M3L6 Schraubenum den Montagerahmen auf den Rändelschrauben zu befestigen.

Schritt 4:

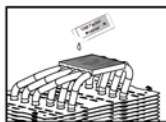

Tragen Sie eine hauchdünne Schicht Wärmeleitpaste auf der Oberfläche der CPU und auf der Unterseite des Kühlers auf.

Schritt 5:

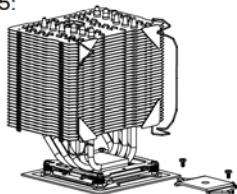

Platzieren Sie nun den Kühlkörper auf die CPU. Führen Sie anschließend die Befestigungsplatte durch den Kühlkörper und benutzen die beide M3L6 Schrauben, um die Befestigungsplatte zu befestigen.

Schritt 6:

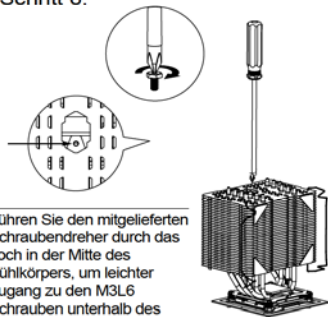

Führen Sie den mitgelieferten Schraubendreher durch das Loch in der Mitte des Kühlkörpers, um leichter Zugang zu den M3L6 Schrauben unterhalb des Kühlers zu erhalten.

Schritt 7:

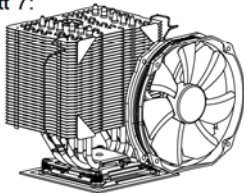

Positionieren Sie den mitgelieferten TY-140 auf die Kühlerseite mit den bereits angebrachten AntiVibrationspads. Nun sichern Sie den Lüfter mit den Lüfterklammern, indem Sie diese über den Lüfterrahmen klappen und die spitzwinkligen Ecken in die Montagelöcher des Lüfters einrasten lassen.

Schritt 8:

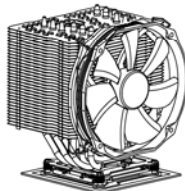

Verbinden Sie den Lüfterstecker mit dem CPU PWM Lüfteranschluss auf dem Mainboard. Die Installation ist nun abgeschlossen. Bitte prüfen Sie die ordnungsgemäße Funktion vor Inbetriebnahme Ihres PC.

Explosionszeichnung

Wichtig! Bitte prüfen Sie vor der Montage, ob für Ihren Kühler aktualisierte Montagehinweise auf der Webseite www.thermalright.com verfügbar sind.

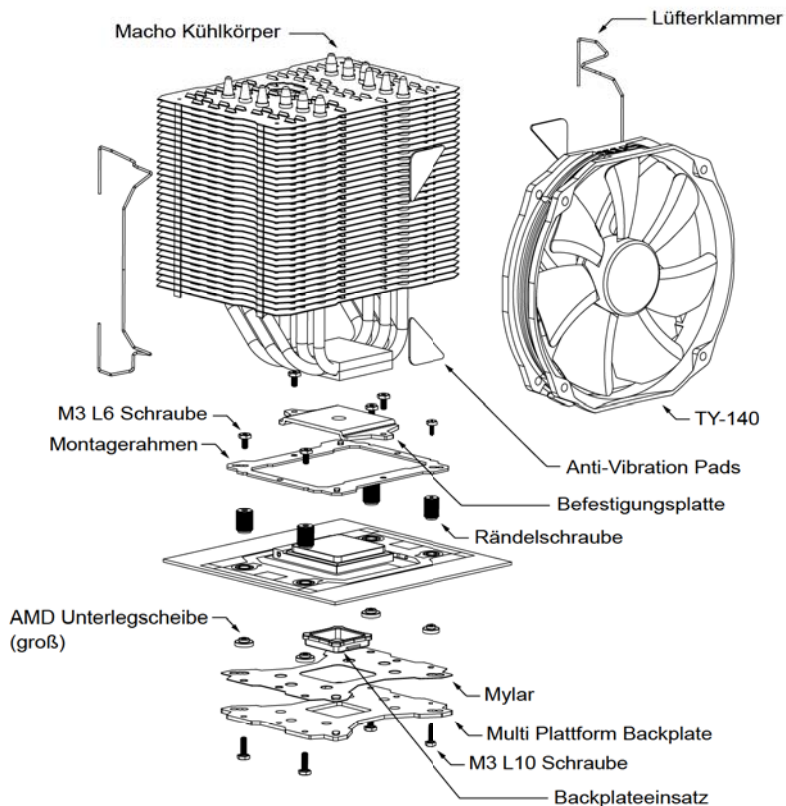

Component

1 Macho Kühlkörper ×1			2 Montagerahmen ×1			3 Multi Plattform Backplate×1		
4 Befestigungsplatte ×1			5 Rändelschraube ×4			6 LGA2011 Type B Adapterschraube x4		
7 M3 L10 Schraube ×5			8 M3 L6 Schraube ×7			9 Intel Unterlegscheibe (klein) ×4		
10 AMD Unterlegscheibe (groß) ×4			11 Anti-Vibrationspad ×4			12 Backplateeinsatz ×1		
13 Lüfterklammer ×2			14 Wärmeleitpaste ×1			15 Schraubendreher ×1		
16 TY-140 ×1			17 Leitschutzfolie ×1					

Installationsanleitung:

Schritt 1:

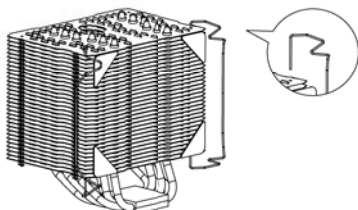

Nachdem Sie den Macho Kühler aus der Verpackung genommen haben demontieren Sie zunächst den Lüfter, um die Installation zu vereinfachen. Belassen Sie hierbei die Lüfterklammern am Kühlkörper - entfernen Sie diese nicht. Bringen Sie die vier selbstklebenden Anti-Vibrationspads an den Ecken des Kühlkörpers an.

Schritt 2:

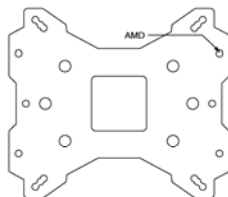
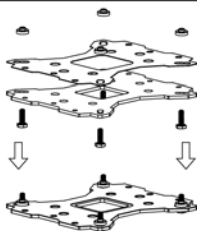

Achten Sie auf die für den AMD Sockel vorgesehene Bohrungen in der Multi Plattform Backplate. Führen Sie die vier M3L10 Schrauben jeweils vor unten durch die Backplate und die mitgelieferte Leitschutzfolie und legen dann die Backplate auf den Tisch. Legen Sie die vier Unterlegscheiben (für AMD) über die hervorstehenden Gewinde.

Schritt 3:

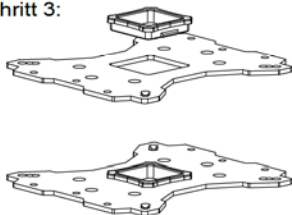

Schritt 4:

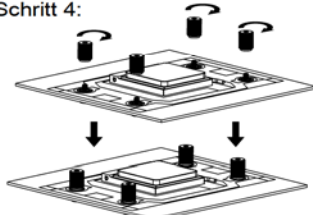

Bei Verwendung einer AMD Sockel 939 Plattform setzen Sie zuerst den Backplateeinsatz in die quadratische Öffnung der Backplate ein. Gehen Sie sicher, dass der Aufsatz nach unten zeigt.

Platzieren Sie das Mainboard von oben auf die Backplate, so dass die hervorstehenden Schraubengewinde durch die Löcher um den Prozessorsockel gehen. Schrauben Sie die beiliegenden Rändelschrauben auf die vier Schraubengewinde. Achten Sie dabei darauf, dass die Seite mit der Unterlegscheibe zur Backplate zeigt.

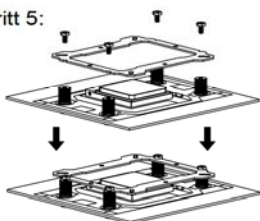
Schritt 5:

Setzen Sie den Montagerahmen auf die Rändelschrauben. Verwenden Sie die vier M3L6 Schrauben, um den Montagerahmen auf den Rändelschrauben zu befestigen.

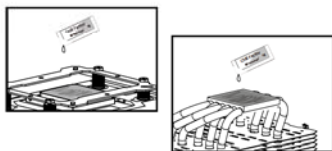
Schritt 6:

Tragen Sie eine hauchdünne Schicht Wärmeleitpaste auf der Oberfläche der CPU und auf der Unterseite des Kühlers auf.

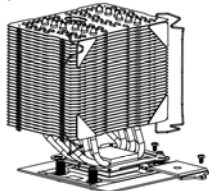
Schritt 7:

Platzieren Sie nun den Kühlkörper auf die CPU. Führen Sie anschließend die Befestigungsplatte durch den Kühlkörper und benutzen die beiden M3L6 Schrauben, um die Befestigungsplatte zu befestigen.

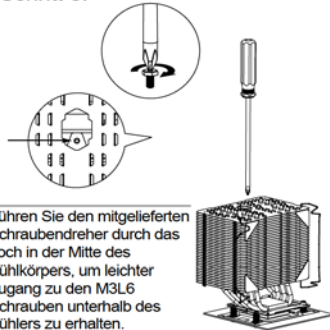
Schritt 8:

Führen Sie den mitgelieferten Schraubendreher durch das Loch in der Mitte des Kühlkörpers, um leichter Zugang zu den M3L6 Schrauben unterhalb des Kühlers zu erhalten.

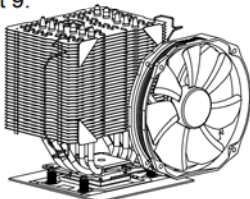
Schritt 9:

Positionieren Sie den mitgelieferten 120mm auf die Kühlerseite mit den bereits angebrachten AntiVibrationspads. Nun sichern Sie den Lüfter mit den Lüfterklammern, indem Sie diese über den Lüfterrahmen klappen und die spitzwinkligen Ecken in die Montagelöcher des Lüfters einrasten lassen.

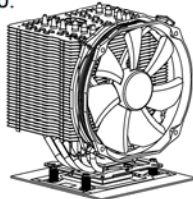
Schritt 10:

Verbinden Sie den Lüfterstecker mit dem CPU PWM Lüfteranschluss auf dem Mainboard. Die Installation ist nun abgeschlossen. Bitte prüfen Sie die ordnungsgemäße Funktion vor Inbetriebnahme Ihres PC.

Technical Spec

Heatsink Specifications:

Dimension: Length 140mm x Width 102mm x Height 162mm

Weight: 710g

Heatpipe: 6mm heatpipe*6 units

Copper Base: C1100 Pure copper nickel plated

Fan Specification:

Dimension: L152mm x H140mm x W26.5mm

Weight: 160g

Fan speed: 900~1300RPM (4-Pin PWM)

Fan noise: 17~21dBA MAX (4-Pin PWM)

Airflow: 28.3~73.6CFM MAX

Connector: 4 Pin (PWM Fan connector)

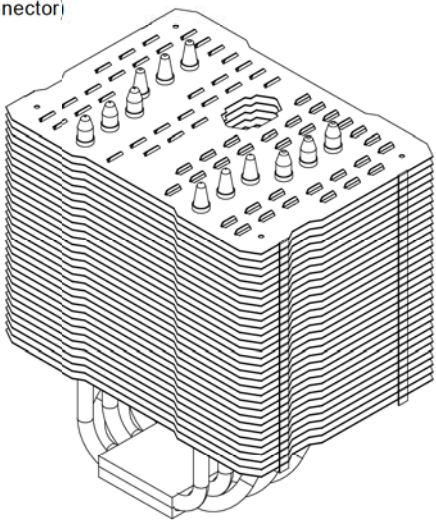

Technische Spezifikationen

Kühlkörper Spezifikationen:

Maße (mm): Länge 140 x Breite 102 x Höhe 162

Gewicht: 710 g

Heatpipe: 6 mm Heatpipe * 6 Stück

Kupfer Grundplatte: C1100 reines Kupfer vernickelt

Lüfter Spezifikationen:

Maße (mm): L152 x H140 x B26,5

Gewicht: 160 g

Drehzahl: 900~1300 U/min (4-Pin PWM)

Lautstärke: 17~21 dBA max. (4-Pin PWM)

Fördermenge: 48,08~125,04 m³/h max.

Anschluss: 4 Pin (PWM Lüfteranschluss)

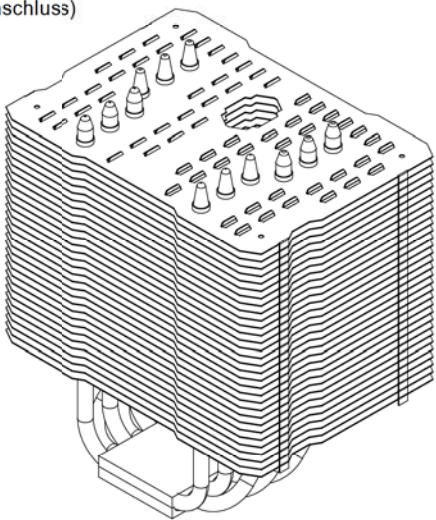

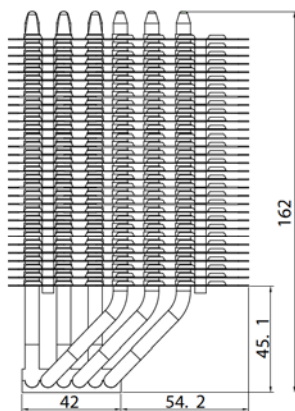
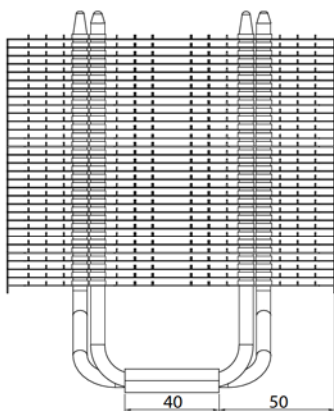
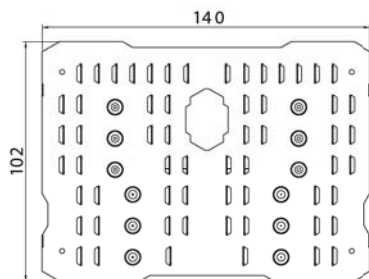

Awards



The Ultimate Cooling Solutions!



Thermalright

www.thermalright.com

TEL: +886-2-8663-6630

FAX: +886-2-8663-6645

EMAIL: sales@thermalright.com