

Thermalright

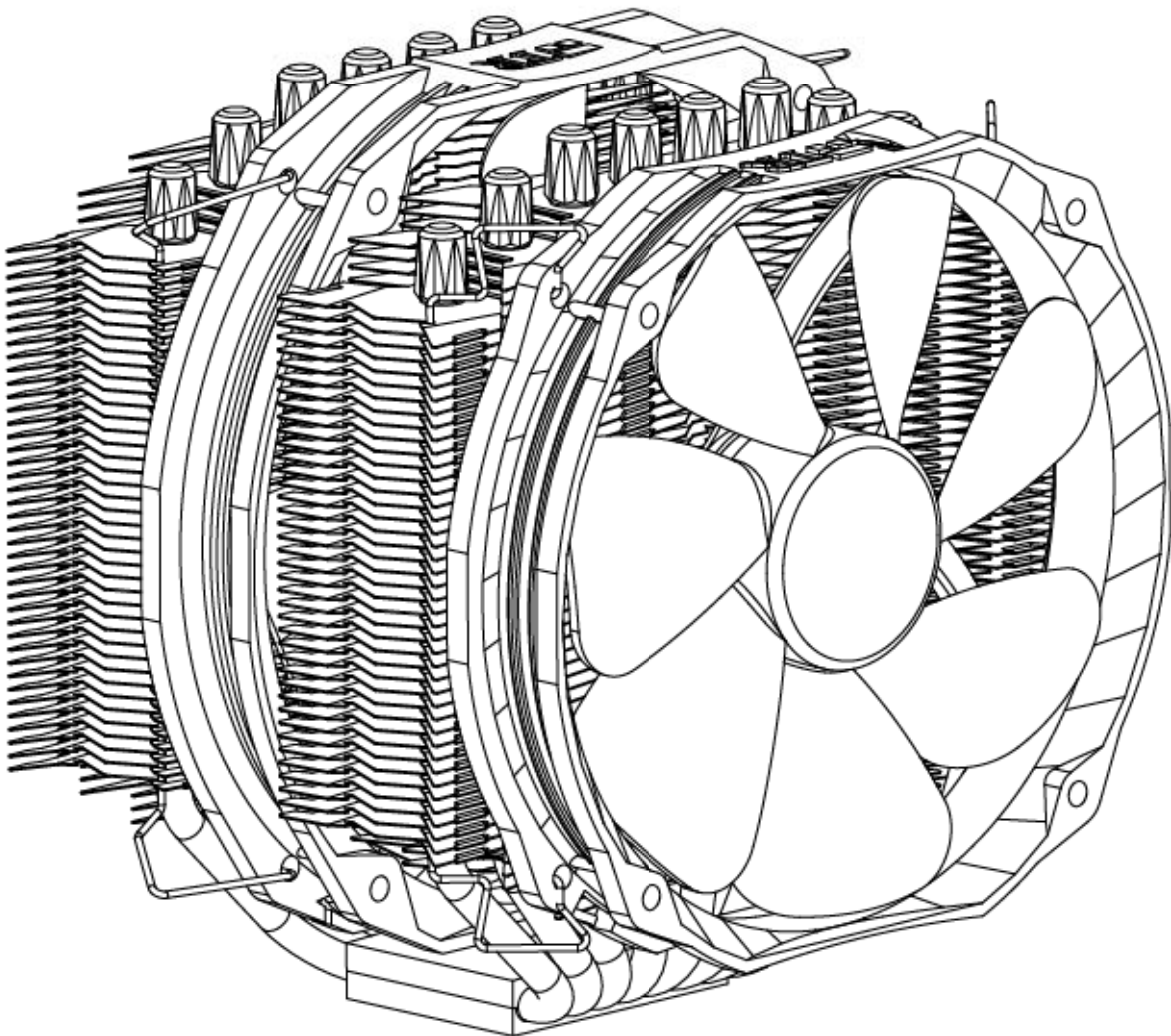

Silver Arrow SB-E



Silver Arrow SB-E

Assembly Package



x 4



x 1



x 4



x 8

4



x 7



x 4



x 5



x 4

4

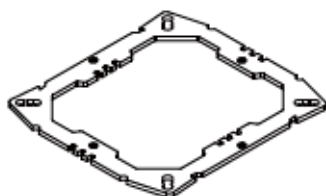

x 1



x 1



x 1



x 4



x 1



x 2



x 1



x 1







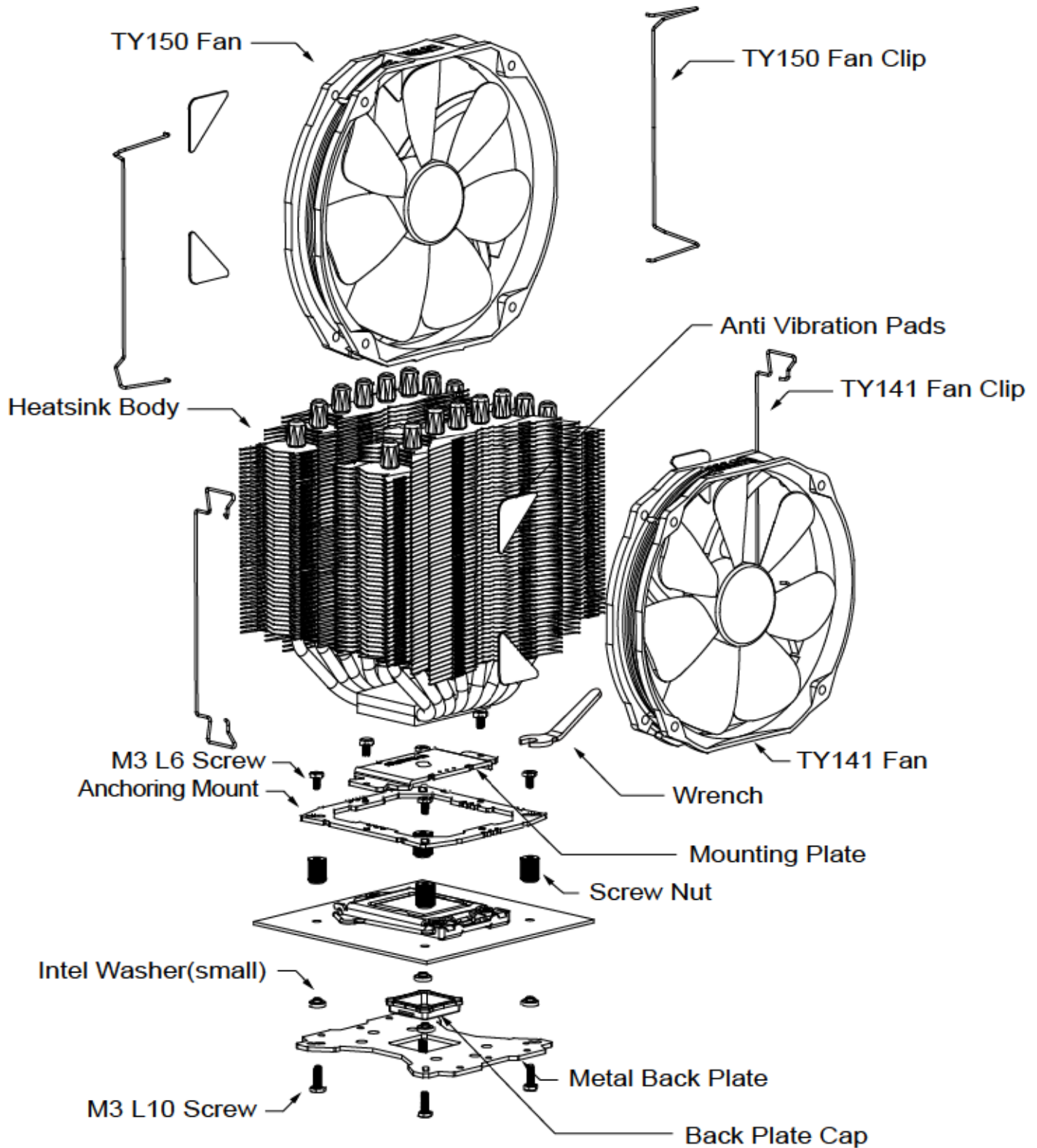



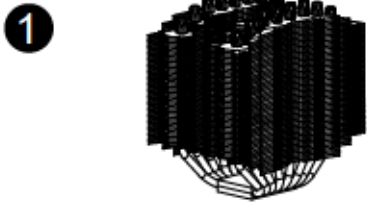
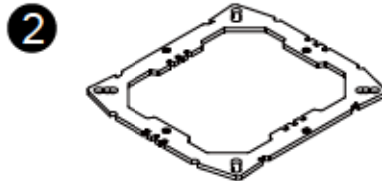
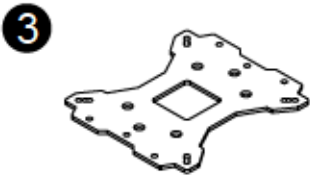

8

Exploded View

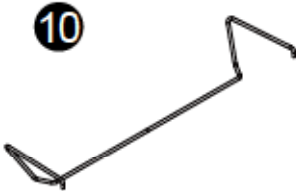
Important! Before proceeding with installation, please check for the most up-to-date instructions at www.thermalright.com

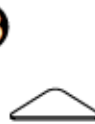

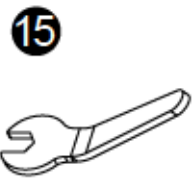
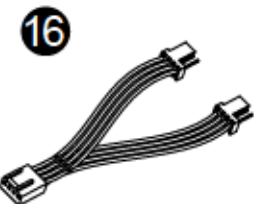
Component

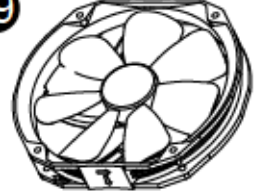
| | | |
|---|--|---|
|  |  |  |
|  |  |  |
|  |  | |
|  |  |  |
| | |  |
| | |  |
| | |  |
|  |  |  |
| |  |  |
| 1 Heatsink Body x1 | 2 Anchoring Mount x1 | 3 Metal Back Plate x1 |
| 4 Mounting Plate x1 | 5 Screw Nut x4 | 6 LGA2011 Type B Screw Pillars x4 |
| 7 M3 L10 Screw x5 | 8 M3 L6 Screw x7 | 9 TY-141 Fan Clip x4 |
| 10 TY-150 Fan Clip x2 | 11 Intel Washer (small) x4 | 12 AMD Washer (big) x4 |
| 13 Anti Vibration Pad x8 | 14 Back Plate Cap x1 | 15 Wrench x1 |
| 16 PWM Y-Cable x1 | 17 Thermal Paste x1 | 18 TY 141 Fan x1 |
| 19 TY 150 Fan x1 | | |

Installation Instructions:

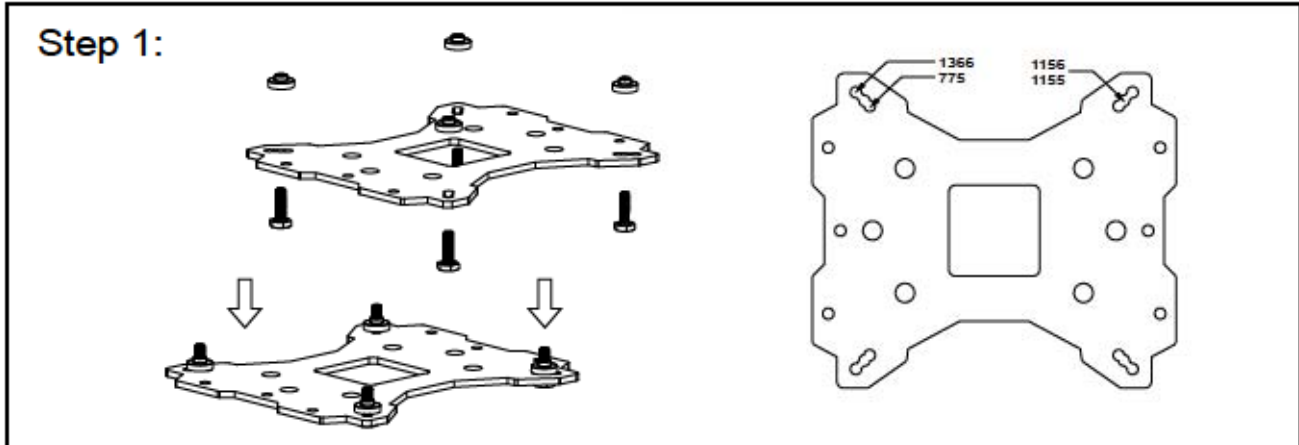

Step 1 : Back Plate Installation

Choose the platform (775/1155/1156/1366) you are in use. Make four M3L10 Screws go through the Metal Back Plate from bottom towards top. And then place the Metal Back Plate on the table. Put the four Washers (for Intel) around the Screw Cylinders.

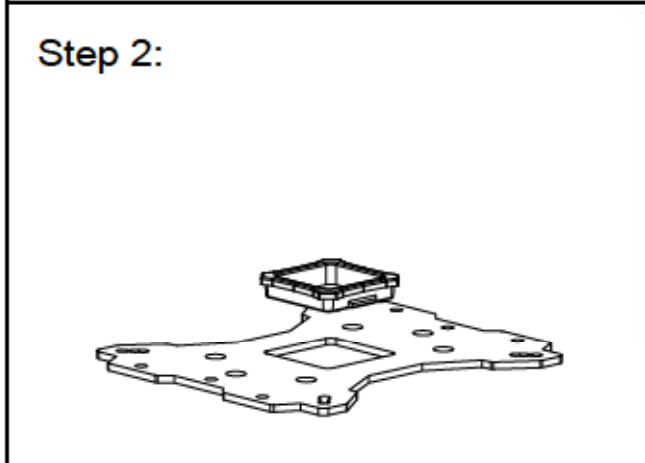

Step 2 : 775 Back Plate Cap

Note: When installing on a 775 platform, please first insert the Back Plate Cap into the opening on the Back plate. Make sure you have the Cap facing downwards. (Only for 775).

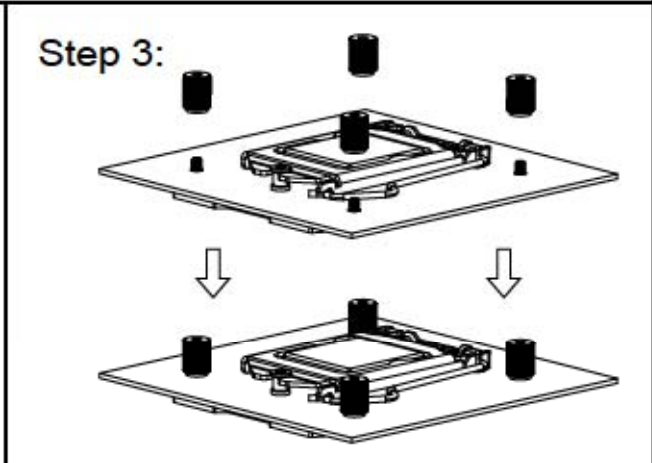

Step 3 : Screw Cylinder Installation

Place the motherboard on top of the Back Plate. See the four Screw Cylinders go through the four holes around the processor socket. Cap the four Screw Cylinders with the four Screw Nuts. Make sure the side with a washer is facing the Back Plate.

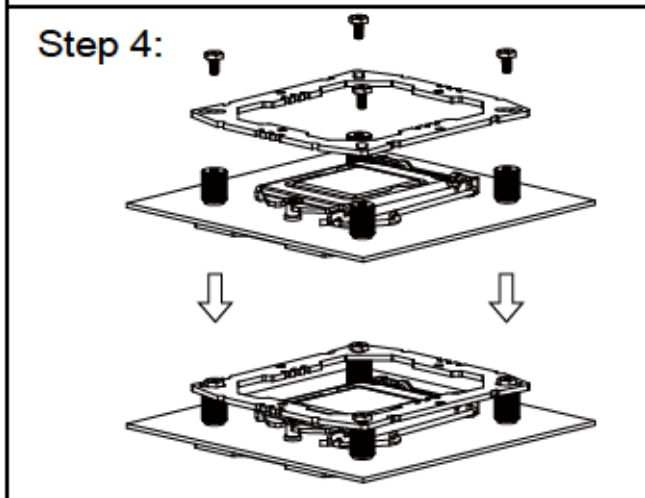

Step 4 : Anchoring Mount Installation

Place the Anchoring Mount on the Screw Nuts. Use the four M3L6 Screws to fix the Anchoring Mount on to the Screw Nuts.

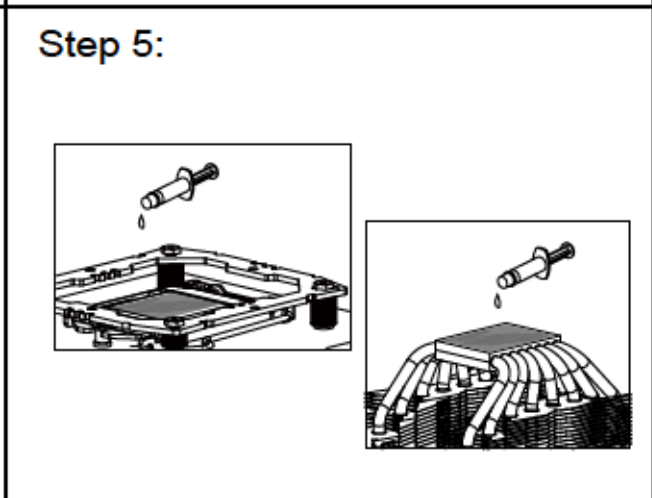

Step 5 : Applying Thermal Paste

Apply the Thermal Paste to the base of the Heatsink and the surface of the CPU evenly.

Step 6:

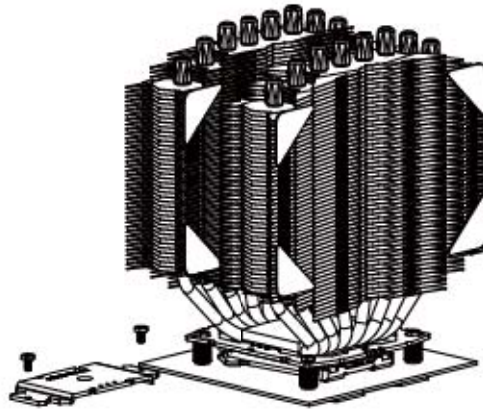

Step 6 : Mounting Plate Installation

Place the Heat Sink Body on top of the CPU. Make the Mounting Plate go through the Heatsink Body. And then use the two M3L6 screws to secure the Mounting Plate.

Step 7:

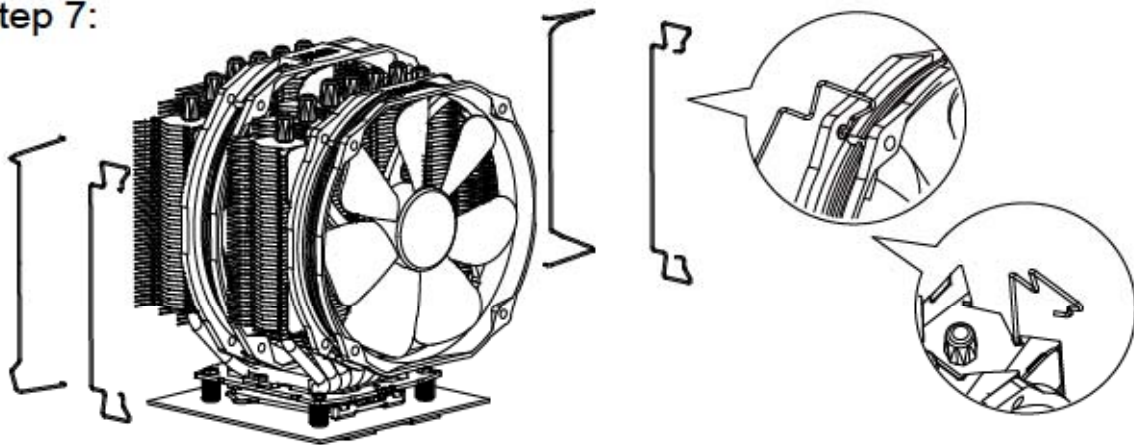

Step 7 : Fan Installation

Pass one end of the TY150 Fan Clip through the mounting hole of the TY-150 Fan. Hook the Fan Clip through the Fan Clip Slot. Pass the end of the Fan Clips through the mounting hole of the TY-150 Fan. Repeat the procedure with the TY141 Fan Clip on the TY-141 Fan.

Step 8:

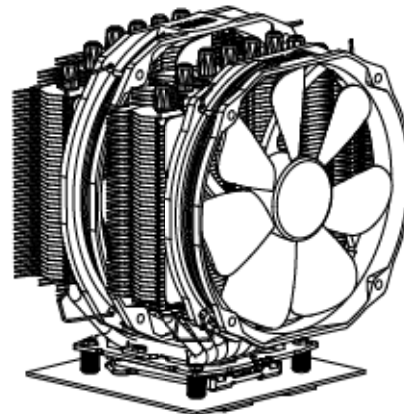

Step 8 : Installation Completed







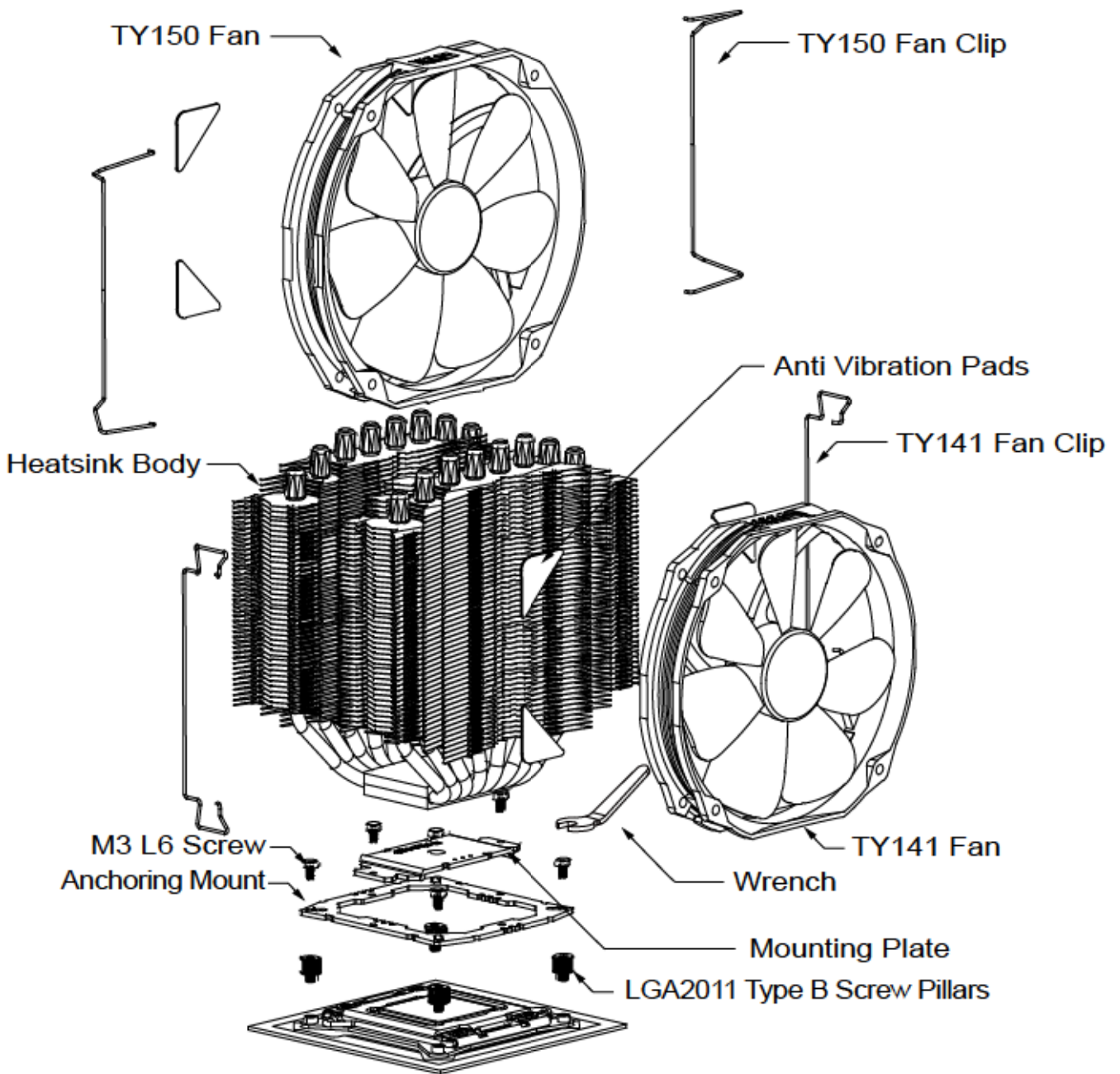



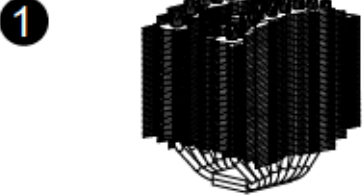
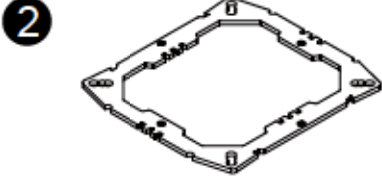
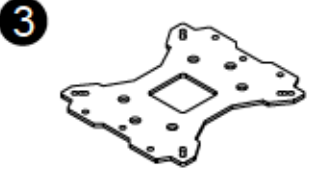

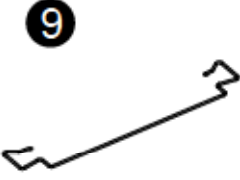
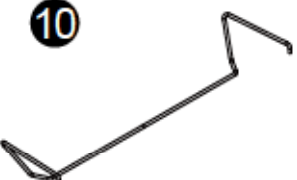

Plug in the fan connector to the CPU PWM Fan socket on the motherboard. Installation complete

Exploded View

Important! Before proceeding with installation, please check for the most up-to-date instructions at www.thermalright.com

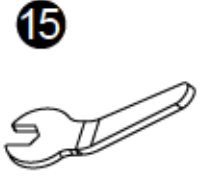
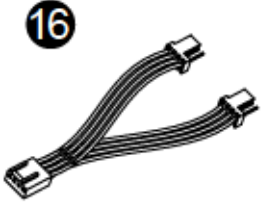

Component

| | | |
|---|--|---|
|  |  |  |
|  |  |  |
|  |  | |
|  |  |  |
| | |  |
| | |  |
| | |  |
|  |  |  |
| |  |  |
| 1 Heatsink Body ×1 | 2 Anchoring Mount ×1 | 3 Metal Back Plate ×1 |
| 4 Mounting Plate ×1 | 5 Screw Nut ×4 | 6 LGA2011 Type B Screw Pillars ×4 |
| 7 M3 L10 Screw ×5 | 8 M3 L6 Screw ×7 | 9 TY-141 Fan Clip ×4 |
| 10 TY-150 Fan Clip ×2 | 11 Intel Washer (small) ×4 | 12 AMD Washer (big) ×4 |
| 13 Anti Vibration Pad ×8 | 14 Back plate Cap ×1 | 15 Wrench ×1 |
| 16 PWM Y-Cable ×1 | 17 Thermal Paste ×1 | 18 TY 141 Fan ×1 |
| 19 TY 150 Fan ×1 | | |

Installation Instructions:

Step 1:

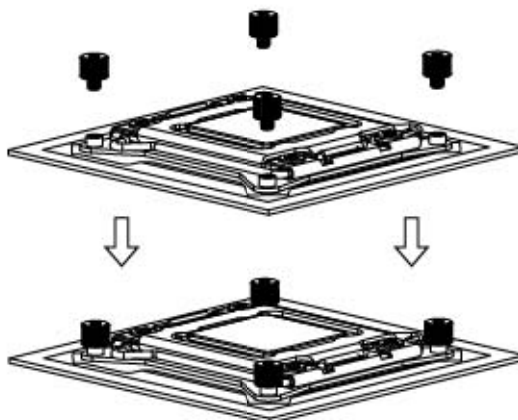

Step 1 : Screw Pillar Installation

Screw on the four LGA2011 Type B Screw Pillars into the Heatsink studs on the ILM Assembly Frame around the processor socket.

Step 2:

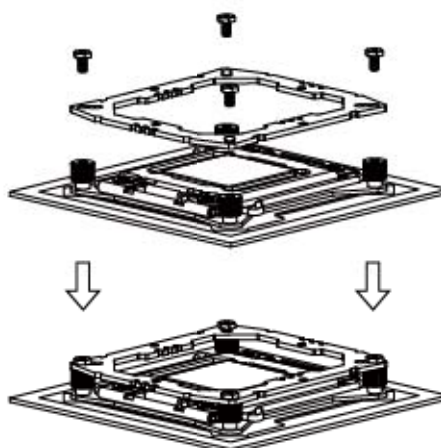

Step 2 : Anchoring Mount Installation

Place the Anchoring Mount onto the four LGA2011 Type B Screw Pillars, secure it by tightening it with 4 M3L6 Screws.

Step 3:

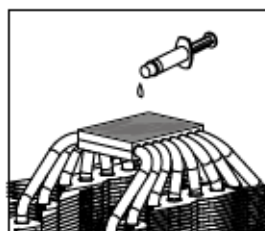
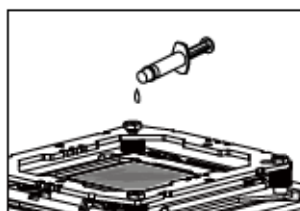

Step 3 : Applying Thermal Paste

Apply the Thermal Paste to the base of the Heatsink and the surface of the CPU evenly.

Step 4:

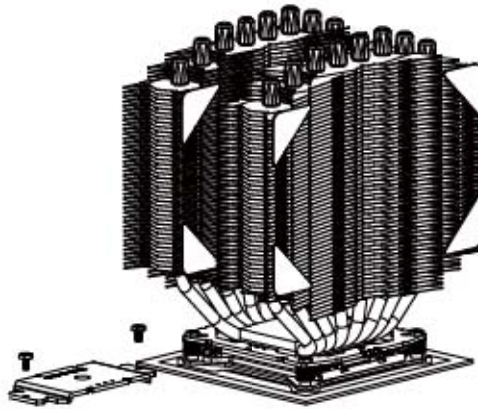

Step 4 : Mounting Plate Installation

Place the Heatsink Body on top of the CPU. Make the Mounting Plate go through the Heatsink Body. And then use the two M3L6 screws to secure the Mounting Plate.

Step 5:

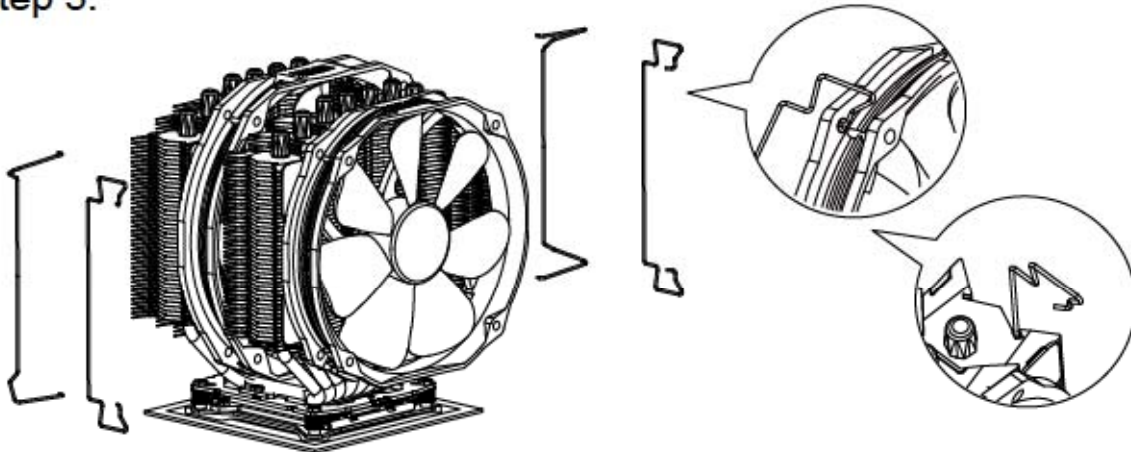

Step 5 : Fan Installation

Pass one end of the TY150 Fan Clip through the mounting hole of the TY-150 Fan. Hook the Fan Clip through the Fan Clip Slot. Pass the end of the Fan Clips through the mounting hole of the TY-150 Fan. Repeat the procedure with the TY141 Fan Clip on the TY-141 Fan.

Step 6:

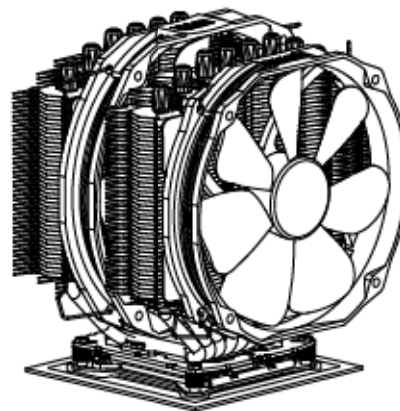

Step 6 : Installation Completed







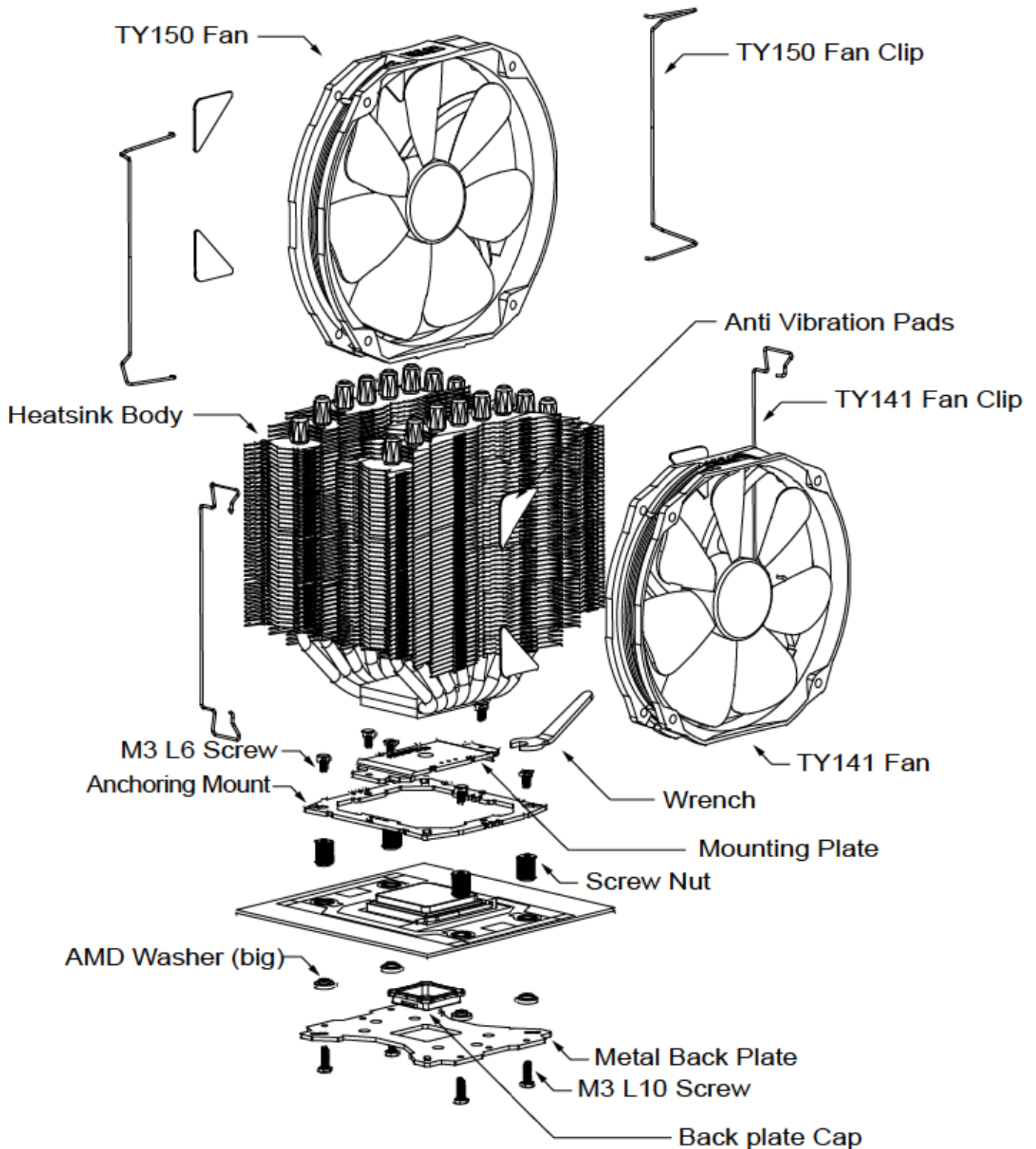



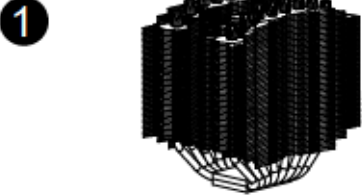
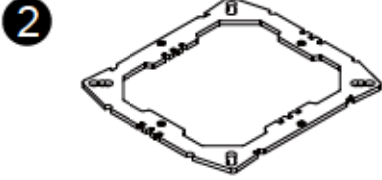
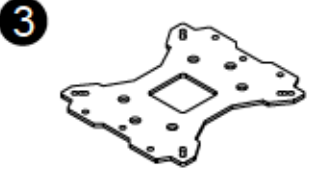

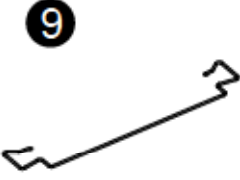
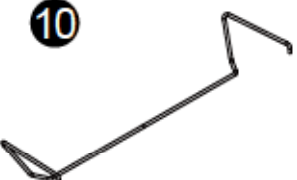

Plug in the fan connector to the CPU PWM Fan socket on the motherboard. Installation complete.

Exploded View

Important! Before proceeding with installation, please check for the most up-to-date instructions at www.thermalright.com

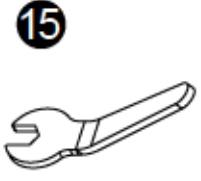
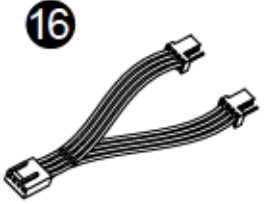

Component

| | | |
|---|--|---|
|  |  |  |
|  |  |  |
|  |  | |
|  |  |  |
| | |  |
| | |  |
| | |  |
|  |  |  |
| |  |  |
| 1 Heatsink Body ×1 | 2 Anchoring Mount ×1 | 3 Metal Back Plate ×1 |
| 4 Mounting Plate ×1 | 5 Screw Nut ×4 | 6 LGA2011 Type B Screw Pillars ×4 |
| 7 M3 L10 Screw ×5 | 8 M3 L6 Screw ×7 | 9 TY-141 Fan Clip ×4 |
| 10 TY-150 Fan Clip ×2 | 11 Intel Washer (small) ×4 | 12 AMD Washer (big) ×4 |
| 13 Anti Vibration Pad ×8 | 14 Back Plate Cap ×1 | 15 Wrench ×1 |
| 16 PWM Y-Cable ×1 | 17 Thermal Paste ×1 | 18 TY 141 Fan ×1 |
| 19 TY 150 Fan ×1 | | |

Installation Instructions:

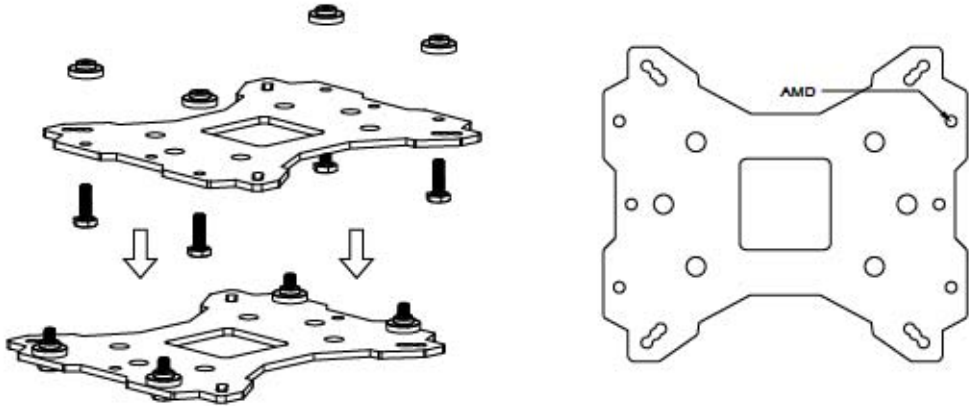
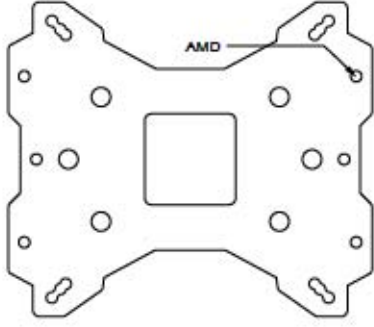
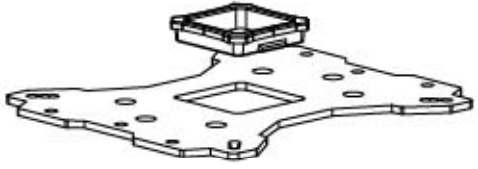
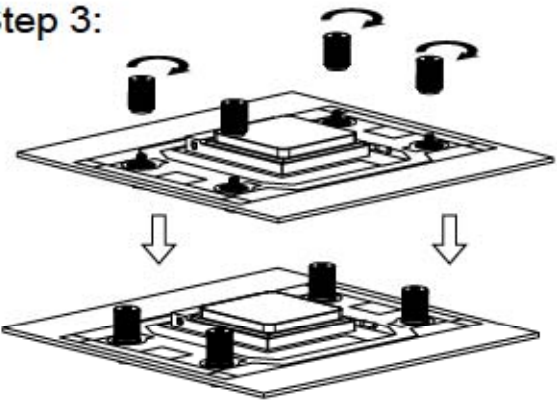
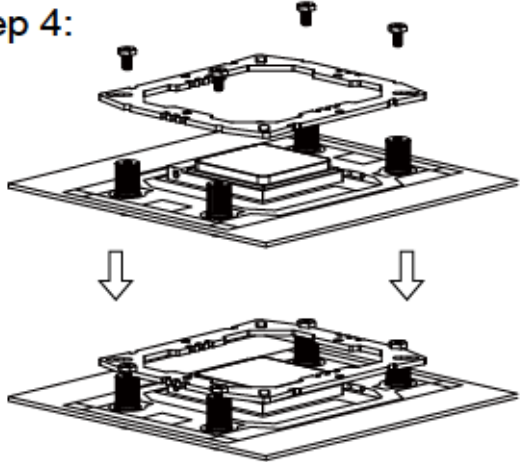
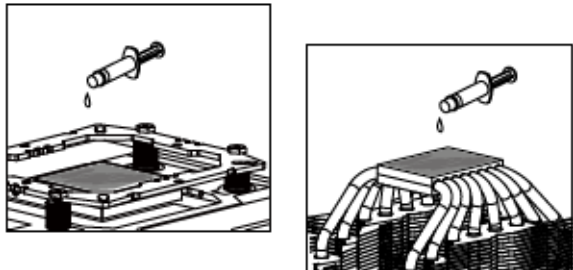
| | |
|--|---|
| <p>Step 1:</p>  |  |
| <p>Step 1 : Back Plate Installation Choose the platform (AMD) you are in use. Make four M3L10 Screws go through the Metal Back Plate from bottom towards top. And then place the Metal Back Plate on the table. Put the four Washers (for AMD) around the Screw Cylinders.</p> | |
| <p>Step 2:</p>  | <p>Step 3:</p>  |
| <p>Step 2 : 939 Back Plate Cap Note: When installing on a 939 platform, please first insert the Back Plate Cap into the opening on the Back plate. Make sure you have the Cap facing downwards. (Only for 939).</p> | <p>Step 3 : Screw Cylinder Installation Place the motherboard on top of the Back Plate. See the four Screw Cylinders go through the four holes around the processor socket. Cap the four Screw Cylinders with the four Screw Nuts. Make sure the side with a washer is facing the Back Plate.</p> |
| <p>Step 4:</p>  | <p>Step 5:</p>  |
| <p>Step 4 : Anchoring Mount Installation Place the Anchoring Mount on the Screw Nuts. Use the four M3L6 Screws to fix the Anchoring Mount on to the Screw Nuts.</p> | <p>Step 5 : Applying Thermal Paste Apply the Thermal Paste to the base of the Heatsink and the surface of the CPU evenly.</p> |

Step 6:

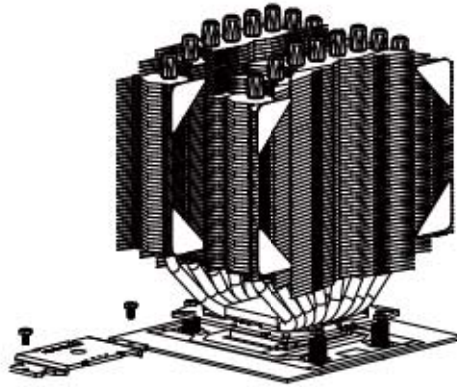

Step 6 : Mounting Plate Installation

Place the Heatsink Body on top of the CPU. Make Mounting Plate go through the Heatsink Body. And then use the two M3L6 screws to secure the Mounting Plate.

Step 7:

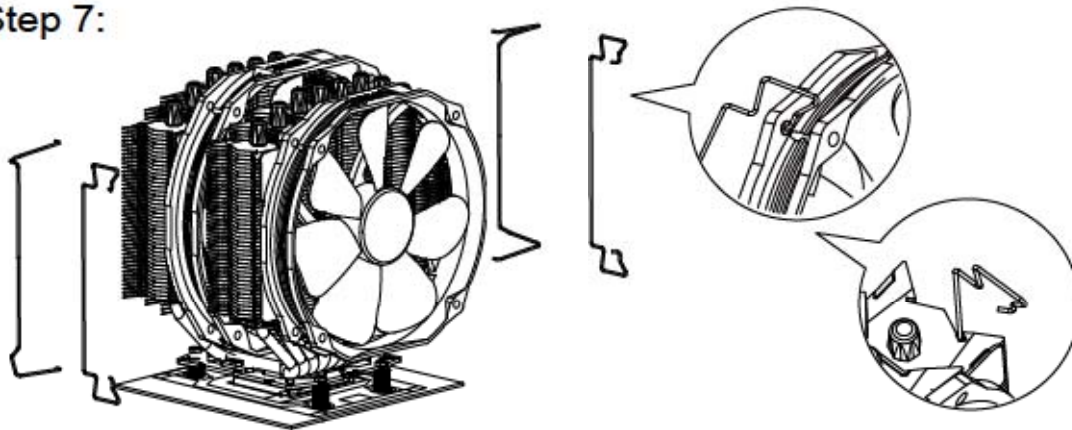

Step 7 : Fan Installation

Pass one end of the TY150 Fan Clip through the mounting hole of the TY-150 Fan. Hook the Fan Clip through the Fan Clip Slot. Pass the end of the Fan Clips through the mounting hole of the TY-150 Fan. Repeat the procedure with the TY141 Fan Clip on the TY-141 Fan.

Step 8:

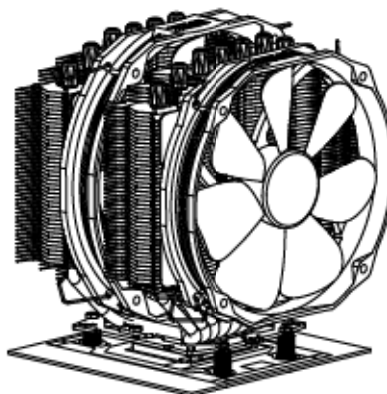

Step 8 : Installation Completed







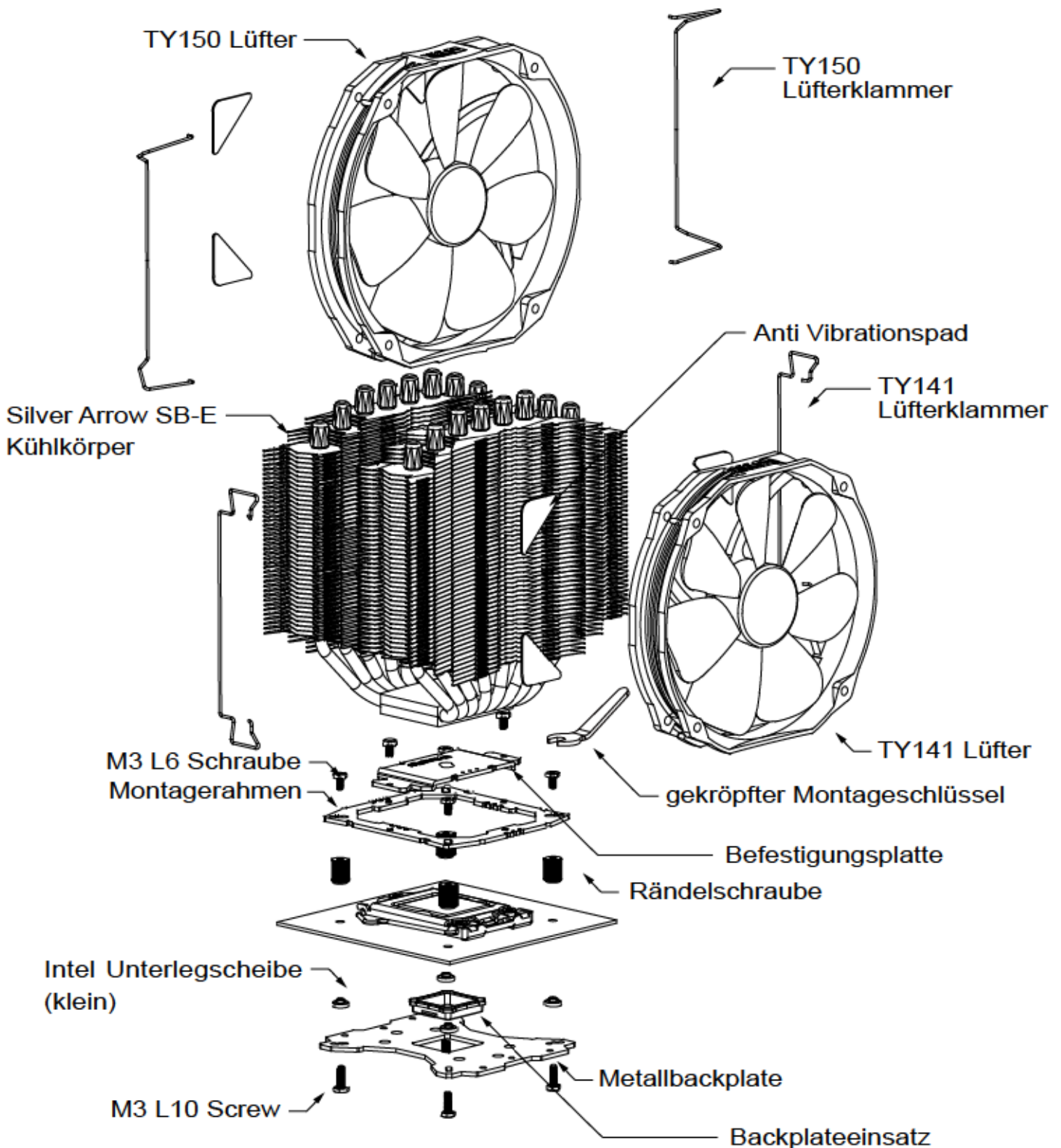



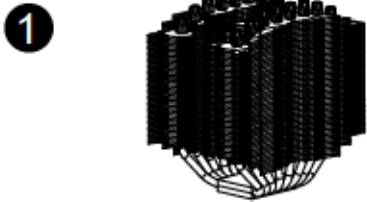
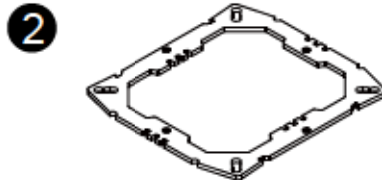
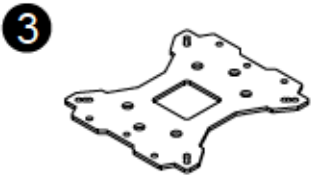

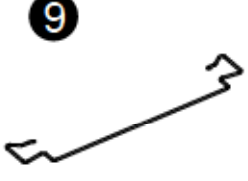
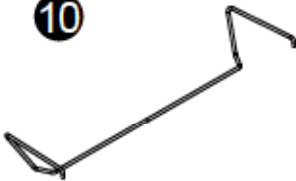

Plug in the fan connector to the CPU PWM Fan socket on the motherboard.

Explosionszeichnung

Wichtig! Bitte prüfen Sie vor der Montage, ob für Ihren Kühler aktualisierte Montagehinweise auf der Webseite www.thermalright.com verfügbar sind.

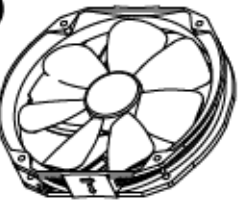

Komponenten

| | | | | | |
|---|---|---|--|---|---|
|  |  |  | | | |
|  |  |  |  |  | |
|  |  |  |  |  |  |
|  |  |  |  |  | |
| 1 Silver Arrow SB-E Kühlkörper x1 | 2 Montagerahmen x1 | 3 Metallbackplate x1 | | | |
| 4 Befestigungsplatte x1 | 5 Rändelschraube x4 | 6 LGA2011 Type B Adapterschraube x4 | | | |
| 7 M3 L10 Schraube x5 | 8 M3 L6 Schraube x7 | 9 TY-141 Lüfterklammer x4 | | | |
| 10 TY-150 Lüfterklammer x2 | 11 Intel Unterlegscheibe (klein) x4 | 12 AMD Unterlegscheibe (groß) x4 | | | |
| 13 Anti Vibrationspad x8 | 14 Backplateeeinsatz x1 | 15 gekröpfter Montageschlüssel x1 | | | |
| 16 PWM Y-Kabel x1 | 17 Wärmeleitpaste x1 | 18 TY 141 Lüfter x1 | | | |
| 19 TY 150 Lüfter x1 | | | | | |

Installationsanleitung:

Schritt 1:

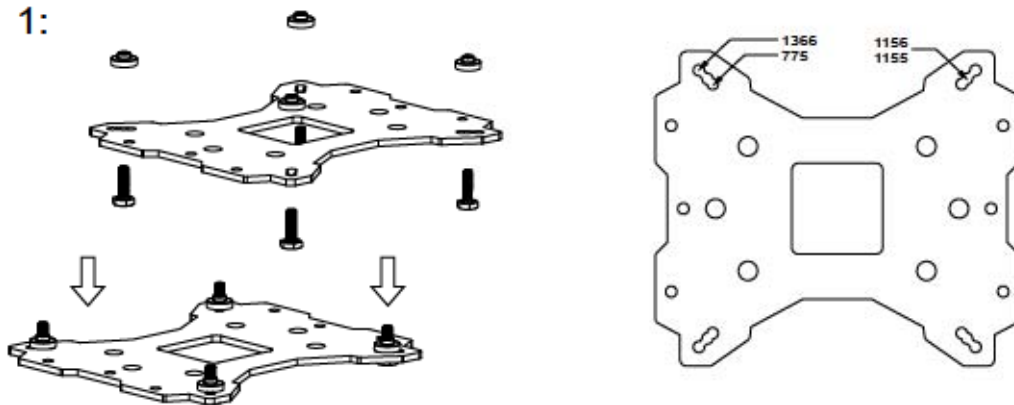

Achten Sie auf die für die entsprechenden Intel Socket (775/1155/1156/1366) vorgesehene Bohrungen in der Multi Plattform Backplate. Führen Sie die vier M3L10 Schrauben jeweils von unten durch diese Bohrungen und legen dann die Backplate auf den Tisch. Legen Sie die vier Unterlegscheiben (für Intel) über die hervorstehenden Gewinde.

Schritt 2:

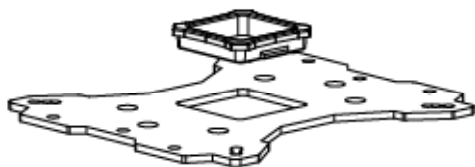

Beachten Sie: Bei Verwendung einer Intel Socket 775 Plattform setzen Sie zuerst den Backplate Aufsatz in die quadratische Öffnung der Backplate ein. Gehen Sie sicher, dass der Aufsatz nach unten zeigt.

Schritt 3:

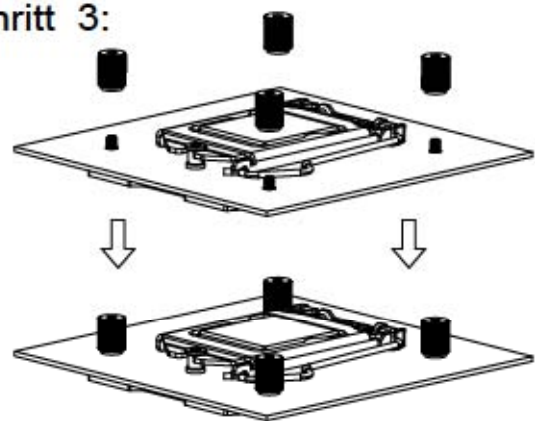

Platzieren Sie das Mainboard von oben auf die Backplate, so dass die hervorstehenden Schraubengewinde durch die Löcher um den Prozessorsocket gehen. Schrauben Sie die Rändelschrauben auf die vier Schraubengewinde. Achten Sie dabei darauf, dass die Seite mit der Unterlegscheibe zur Backplate zeigt.

Schritt 4:

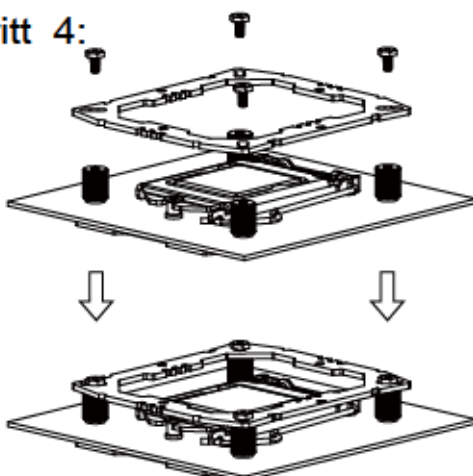

Setzen Sie den Montagerahmen auf die Rändelschrauben. Verwenden die vier M3L6 Schrauben, um den Montagerahmen auf den Rändelschrauben zu befestigen.

Schritt 5:

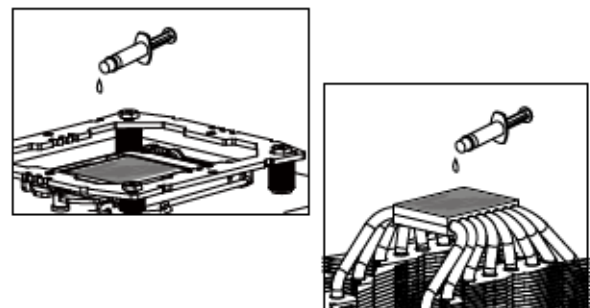

Tragen Sie eine hauchdünne Schicht Wärmeleitpaste auf der Oberfläche der CPU und auf der Unterseite des Kühlers auf.

Schritt 6:

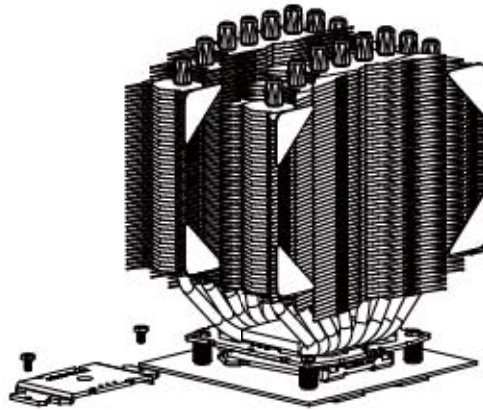

Platzieren Sie nun den Kühlkörper auf die CPU. Führen Sie anschließend die Befestigungsplatte durch den Kühlkörper und benutzen die beiden M3L6 Schrauben, um die Befestigungsplatte zu befestigen.

Schritt 7:

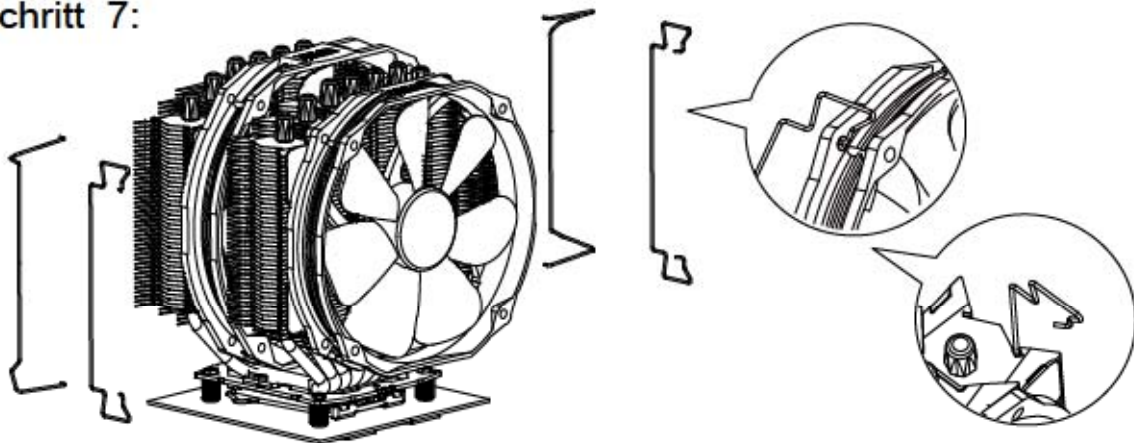

Führen Sie zuerst das untere Ende der Lüfterklammer durch das untere Befestigungsloch des TY-150 Lüfters. Haken Sie nun die Lüfterklammer in den Lüfterklammerschlitz des Kühlkörpers ein. Führen Sie jetzt das obere Ende der Lüfterklammer durch das obere Befestigungsloch des TY-150 Lüfters. Wiederholen Sie den Vorgang bei den TY141 Lüfterklammern auf dem TY-141 Lüfter.

Schritt 8:

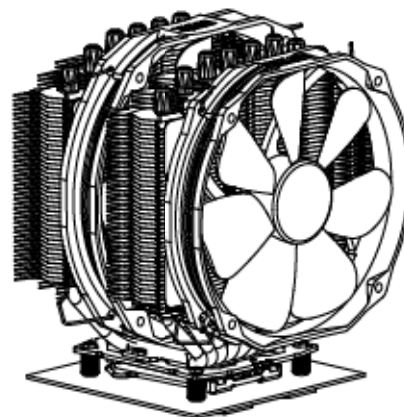







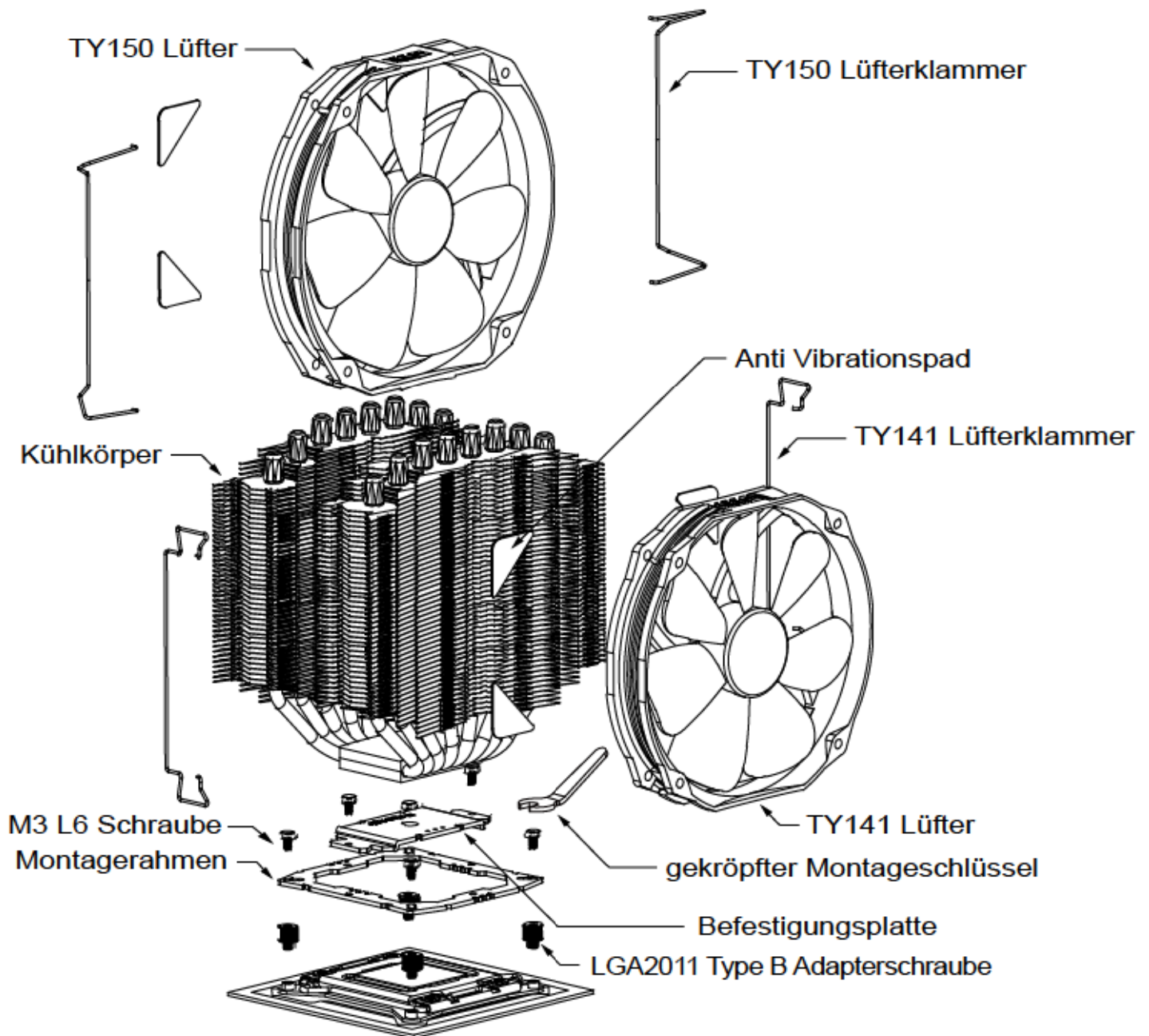

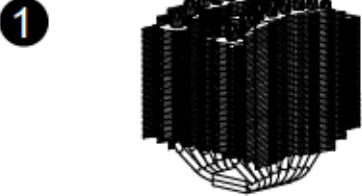
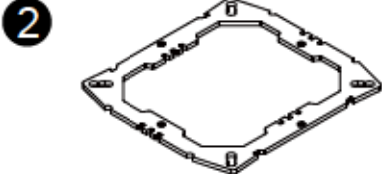
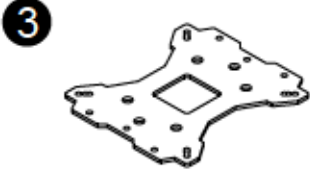

Schließen Sie den Lüfterstecker an den CPU PWM Lüfteranschluss auf dem Mainboard an. Bitte prüfen Sie die ordnungsgemäße Funktion vor der Inbetriebnahme Ihres PC. Die Installation ist abgeschlossen.

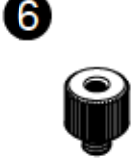
Explosionszeichnung

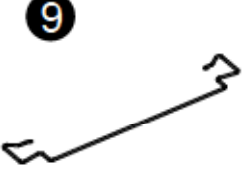
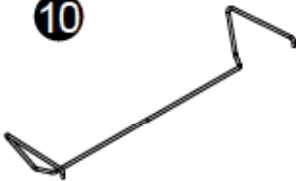
Wichtig! Bitte prüfen Sie vor der Montage, ob für Ihren Kühler aktualisierte Montagehinweise auf der Webseite www.thermalright.com verfügbar sind.

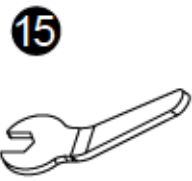
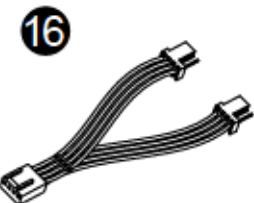

Komponenten

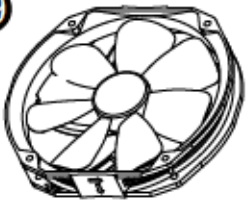
| | | | | | |
|---|---|---|--|---|---|
|  |  |  | | | |
|  |  |  |  |  | |
|  |  |  |  |  |  |
|  |  |  |  |  | |
| 1 Silver Arrow SB-E Kühlkörper x1 | 2 Montagerahmen x1 | 3 Metallbackplate x1 | | | |
| 4 Befestigungsplatte x1 | 5 Rändelschraube x4 | 6 LGA2011 Type B Adapterschraube x4 | | | |
| 7 M3 L10 Schraube x5 | 8 M3 L6 Schraube x7 | 9 TY-141 Lüfterklammer x4 | | | |
| 10 TY-150 Lüfterklammer x2 | 11 Intel Unterlegscheibe (klein) x4 | 12 AMD Unterlegscheibe (groß) x4 | | | |
| 13 Anti Vibrationspad x8 | 14 Backplateeeinsatz x1 | 15 gekröpfter Montageschlüssel x1 | | | |
| 16 PWM Y-Kabel x1 | 17 Wärmeleitpaste x1 | 18 TY 141 Lüfter x1 | | | |
| 19 TY 150 Lüfter x1 | | | | | |

Installationsanleitung:

Schritt 1:

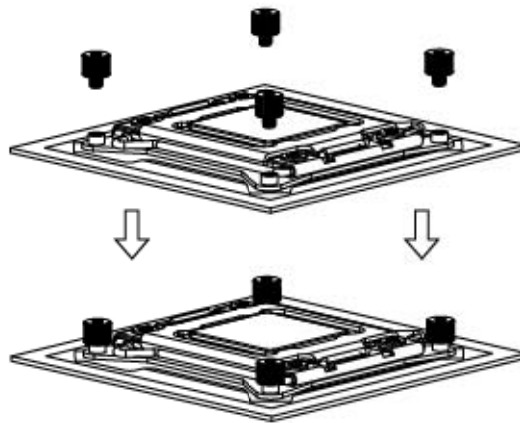

Schrauben Sie die vier LGA2011 Type B Adapterschrauben in die Gewinde des ILM Montagerahmens, der sich um den Prozessorsockel befindet.

Schritt 2:

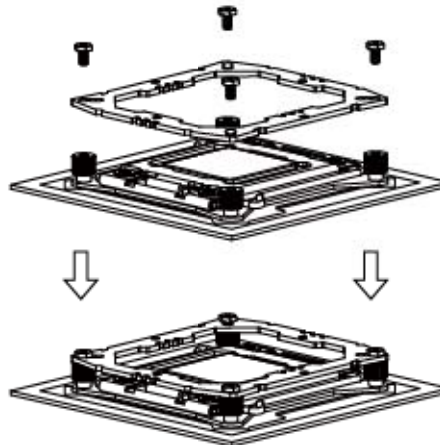

Platzieren Sie den Befestigungsrahmen auf die LGA2011 Type B Adapterschrauben und fixieren ihn mit vier M3L6 Schrauben.

Schritt 3:

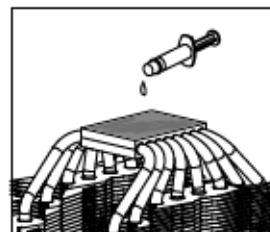
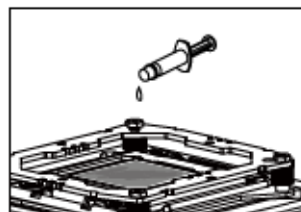

Tragen Sie eine hauchdünne Schicht Wärmeleitpaste auf der Oberfläche der CPU und auf der Unterseite des Kühlers auf.

Schritt 4:

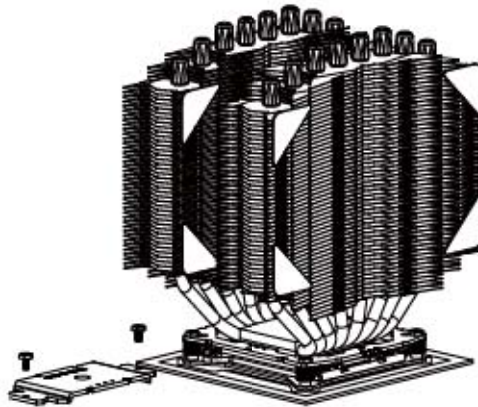

Platzieren Sie nun den Kühlkörper auf die CPU. Führen Sie anschließend die Befestigungsplatte durch den Kühlkörper und benutzen die beiden M3L6 Schrauben, um die Befestigungsplatte zu befestigen.

Schritt 5:

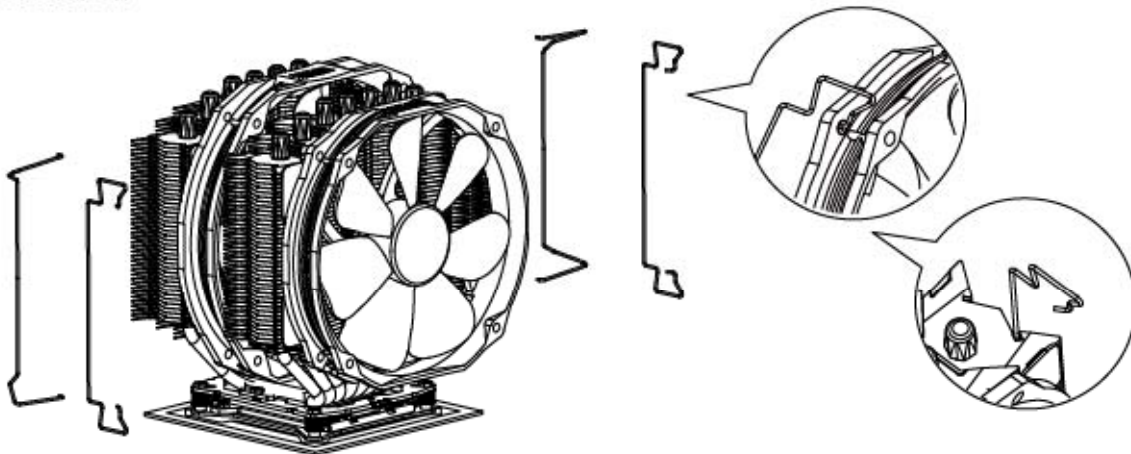

Führen Sie zuerst das untere Ende der Lüfterklammer durch das untere Befestigungsloch des TY-150 Lüfters. Haken Sie nun die Lüfterklammer in den Lüfterklammerschlitze des Kühlkörpers ein. Führen Sie jetzt das obere Ende der Lüfterklammer durch das obere Befestigungsloch des TY-150 Lüfters. Wiederholen Sie den Vorgang bei den TY141 Lüfterklammern auf dem TY-141 Lüfter.

Schritt 6:

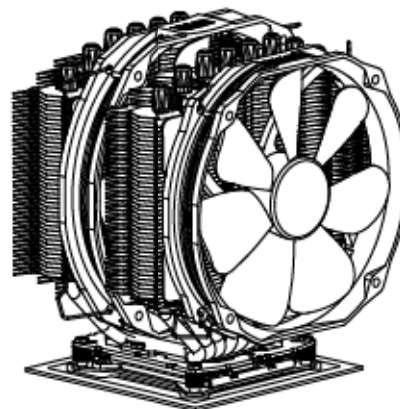







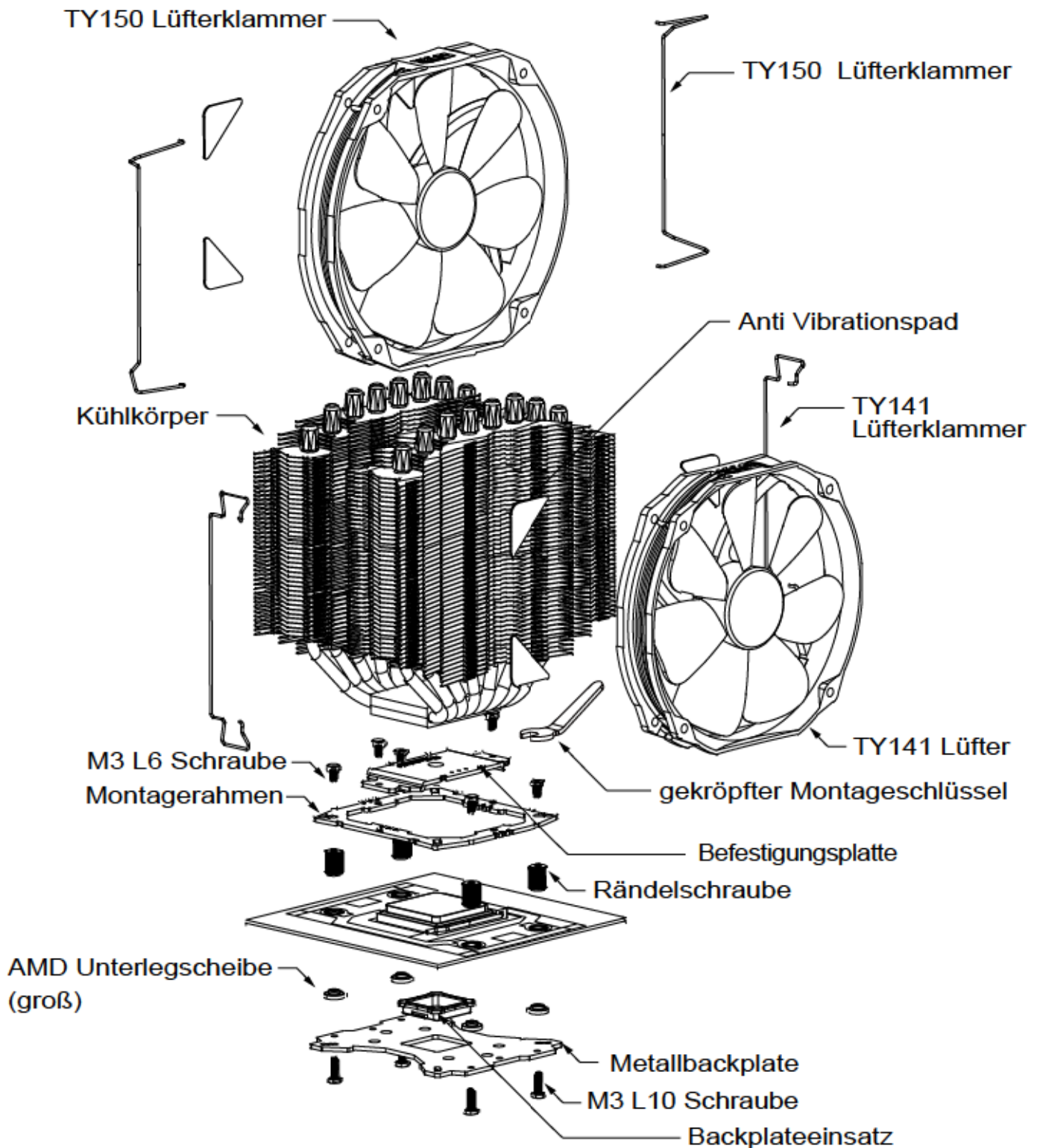



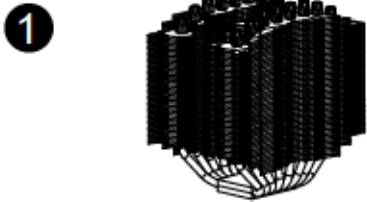
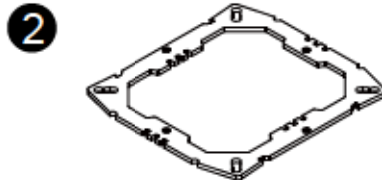
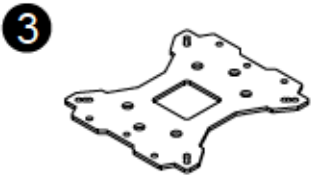

Schließen Sie den Lüfterstecker an den CPU PWM Lüfteranschluss auf dem Mainboard an. Bitte prüfen Sie die ordnungsgemäße Funktion vor der Inbetriebnahme Ihres PC. Die Installation ist abgeschlossen.

Explosionszeichnung

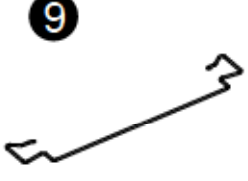
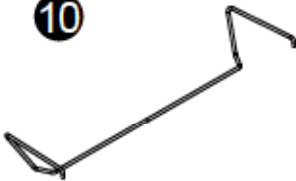
Wichtig! Bitte prüfen Sie vor der Montage, ob für Ihren Kühler aktualisierte Montagehinweise auf der Webseite www.thermalright.com verfügbar sind.

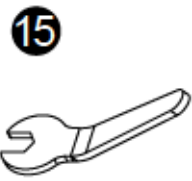
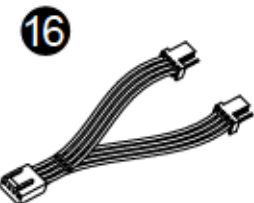

Komponenten

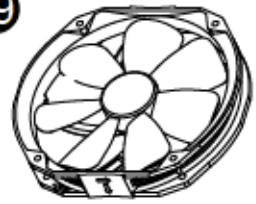
| | | | | | |
|---|---|---|--|---|---|
|  |  |  | | | |
|  |  |  |  |  | |
|  |  |  |  |  |  |
|  |  |  |  |  | |
| 1 Silver Arrow SB-E Kühlkörper x1 | 2 Montagerahmen x1 | 3 Metallbackplate x1 | | | |
| 4 Befestigungsplatte x1 | 5 Rändelschraube x4 | 6 LGA2011 Type B Adapterschraube x4 | | | |
| 7 M3 L10 Schraube x5 | 8 M3 L6 Schraube x7 | 9 TY-141 Lüfterklammer x4 | | | |
| 10 TY-150 Lüfterklammer x2 | 11 Intel Unterlegscheibe (klein) x4 | 12 AMD Unterlegscheibe (groß) x4 | | | |
| 13 Anti Vibrationspad x8 | 14 Backplateeeinsatz x1 | 15 gekröpfter Montageschlüssel x1 | | | |
| 16 PWM Y-Kabel x1 | 17 Wärmeleitpaste x1 | 18 TY 141 Lüfter x1 | | | |
| 19 TY 150 Lüfter x1 | | | | | |

Installationsanleitung:

Schritt 1:

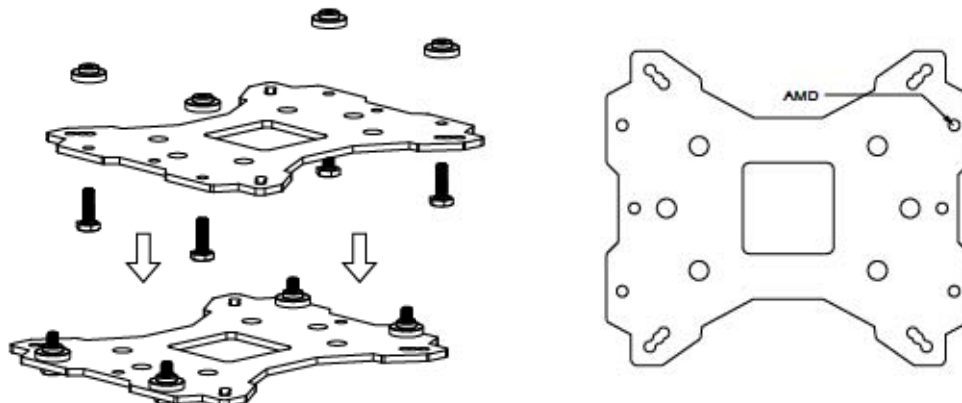

Achten Sie auf die für AMD Sockel vorgesehene Bohrungen in der Multi Plattform Backplate. Führen Sie die vier M3L10 Schrauben jeweils von unten durch diese Bohrungen und legen dann die Backplate auf den Tisch. Legen Sie die vier Unterlegscheiben (für AMD) über die hervorstehenden Gewinde.

Schritt 2:

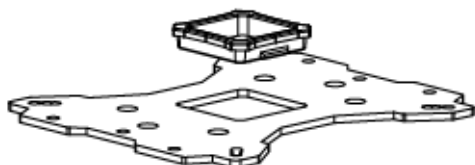

Beachten Sie: Bei Verwendung einer AMD Sockel 939 Plattform setzen Sie zuerst den Backplate Aufsatz in die quadratische Öffnung der Backplate ein. Gehen Sie sicher, dass der Aufsatz nach unten zeigt.

Schritt 3:

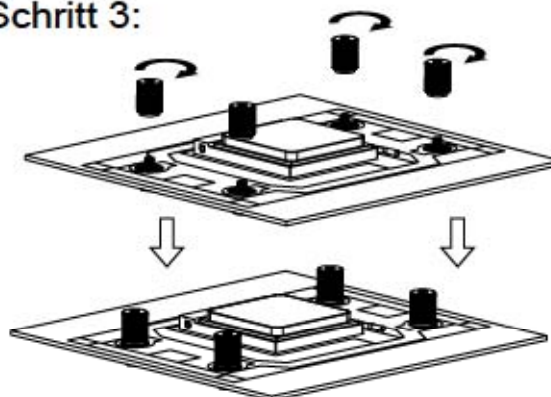

Platzieren Sie das Mainboard von oben auf die Backplate, so dass die hervorstehenden Schraubengewinde durch die Löcher um den Prozessorsocket gehen. Schrauben Sie die beiliegenden auf die vier Schraubengewinde. Achten Sie dabei darauf, dass die Seite mit der Unterlegscheibe zur Backplate zeigt.

Schritt 4:

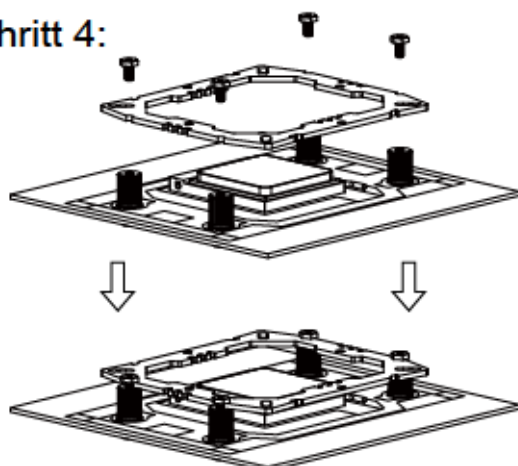

Setzen Sie den Montagerahmen auf die Rändelschrauben. Verwenden Sie die vier M3L6 Schrauben, um den Montagerahmen auf den Rändelschrauben zu befestigen.

Schritt 5:

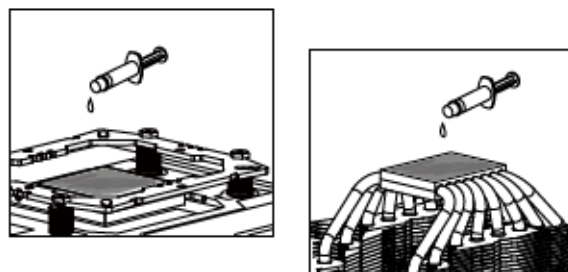

Tragen Sie eine hauchdünne Schicht Wärmeleitpaste auf der Oberfläche der CPU und auf der Unterseite des Kühlers auf.

Schritt 6:

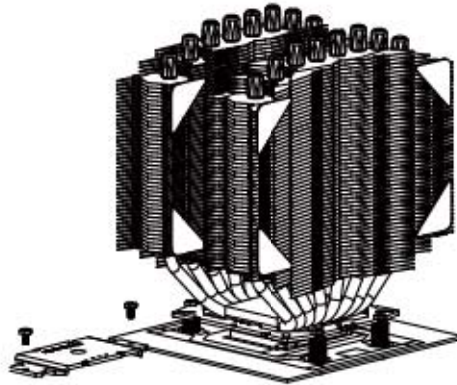

Platzieren Sie nun den Kühlkörper auf die CPU. Führen Sie anschließend die Befestigungsplatte durch den Kühlkörper und benutzen die beiden M3L6 Schrauben, um die Befestigungsplatte zu befestigen.

Schritt 7:

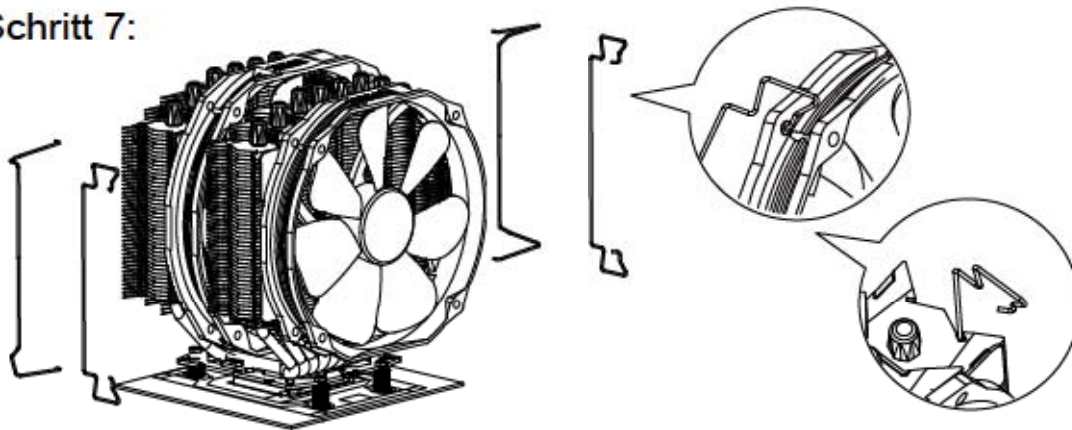

Führen Sie zuerst das untere Ende der Lüfterklammer durch das untere Befestigungsloch des TY-150 Lüfters. Haken Sie nun die Lüfterklammer in den Lüfterklammerschlitze des Kühlkörpers ein. Führen Sie jetzt das obere Ende der Lüfterklammer durch das obere Befestigungsloch des TY-150 Lüfters. Wiederholen Sie den Vorgang bei den TY141 Lüfterklammern auf dem TY-141 Lüfter.

Schritt 8:

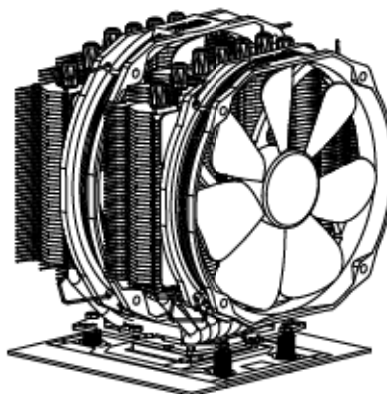

Schließen Sie den Lüfterstecker an den CPU PWM Lüfteranschluss auf dem Mainboard an. Bitte prüfen Sie die ordnungsgemäße Funktion vor der Inbetriebnahme Ihres PC. Die Installation ist abgeschlossen.

The Ultimate Cooling Solutions!



Thermalright
www.thermalright.com

TEL: +886-2-8663-6630

FAX: +886-2-8663-6645

EMAIL: sales@thermalright.com